



OFFICE PLANNER

ARCH



Loose Furniture Collection

ARCH SERIES



CREATING WORK GEMS

Office Concept

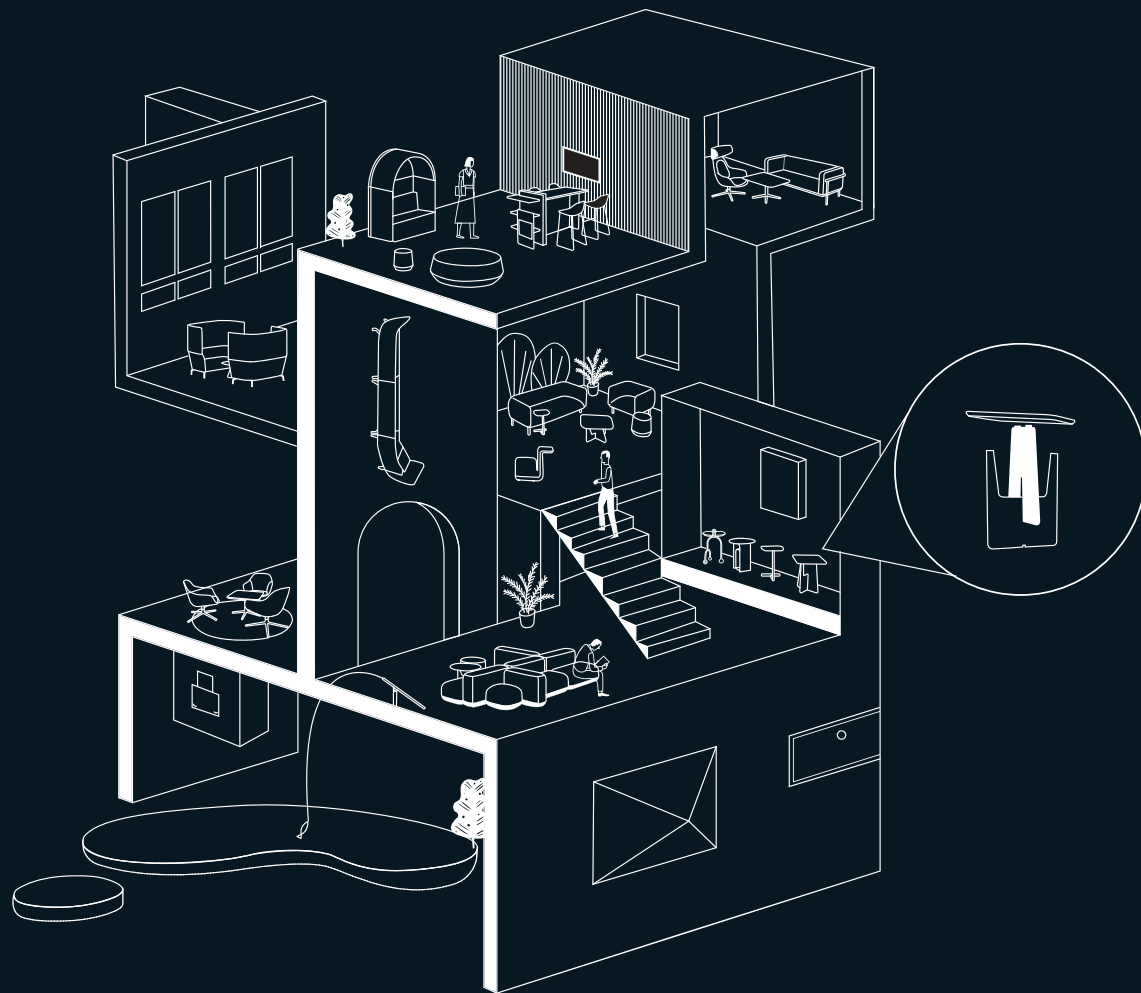

"BUILDING IN THE BUILDING"

CONTENTS

SOFA

QITA	06
MOON	18
CUT	28
LIBERTY	38
LINE	48
MULTI	58
SANTO	68
SHEEP	88
SQUARE	106
MELLO	114
CITY	120
KAS	130
ROMA	140

CHAIR & LOUNGE

BREAD	150
UP	160
FLY SIDE	170
FLY	188
ET	200
ALGER	208
SYS	216
BEAN	230
SHELL	236

POUF 墩

PIPE	244
BAG	252
BUONO	258

TABLE & COFFEE TABLE

MELLO	268
COLLAR	272
PLANK	282
ORIGIN	288

ACCESSORIES

WHALE	294
TAIL	298
MACARON	302
FAN	306

NEW DESIGNS 2021

Product Overview

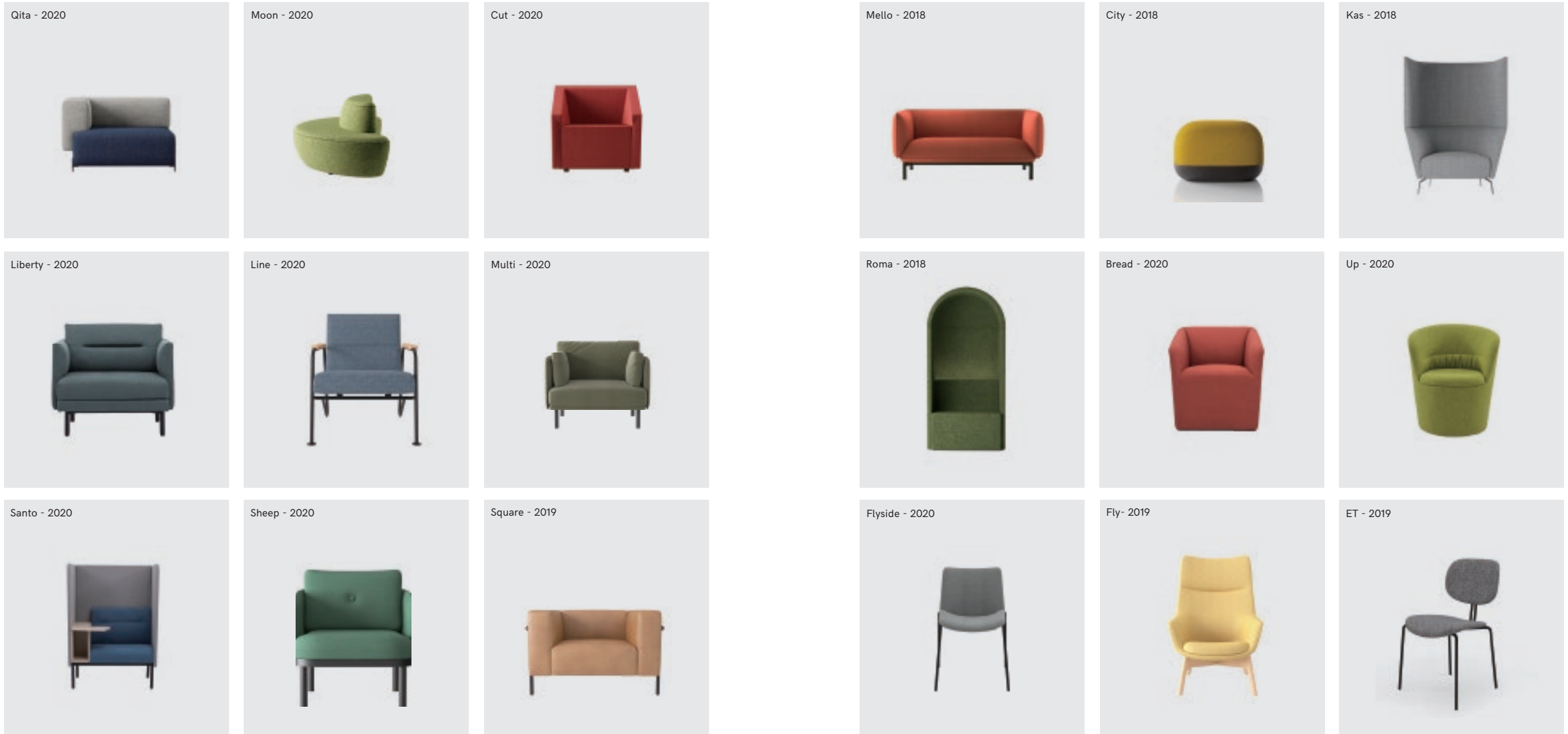

Product Overview

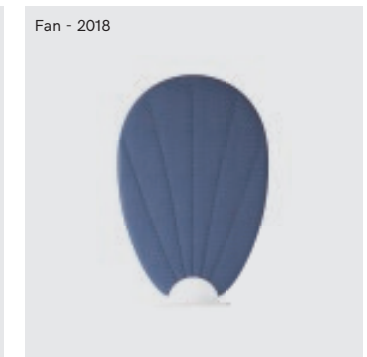
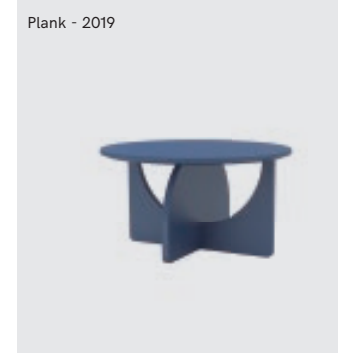
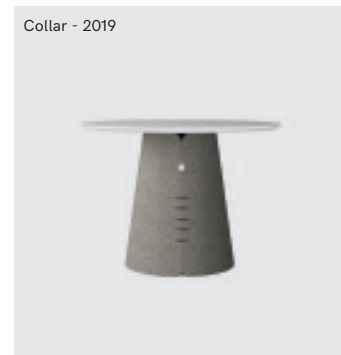
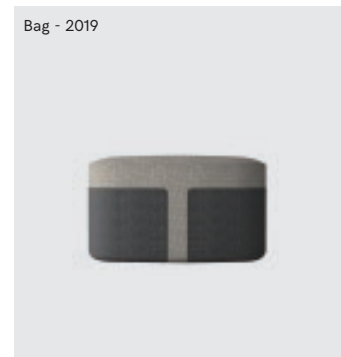
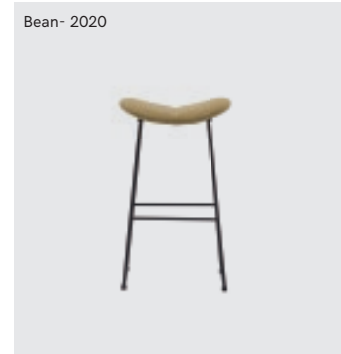



QITA

Design by Collectivo
2020

Qita sofa is a Bauhaus style furniture product. It takes Tetris as the image, deletes unnecessary decorative elements, and pursues the perfect unity of geometric minimalist shape and comfortable function.

The cantilevered backrest armrest makes the product appear light and exquisite, showing rich levels from all angles; The rounded corner treatment makes the geometric sofa more soft and comfortable; The color matching selection of backrest and cushion and the color matching between different modules also provide users with richer and more interesting play space.

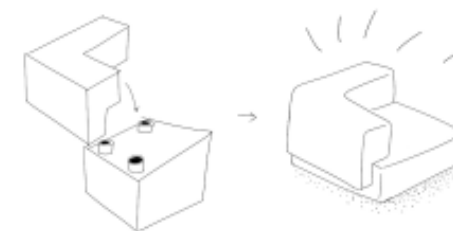







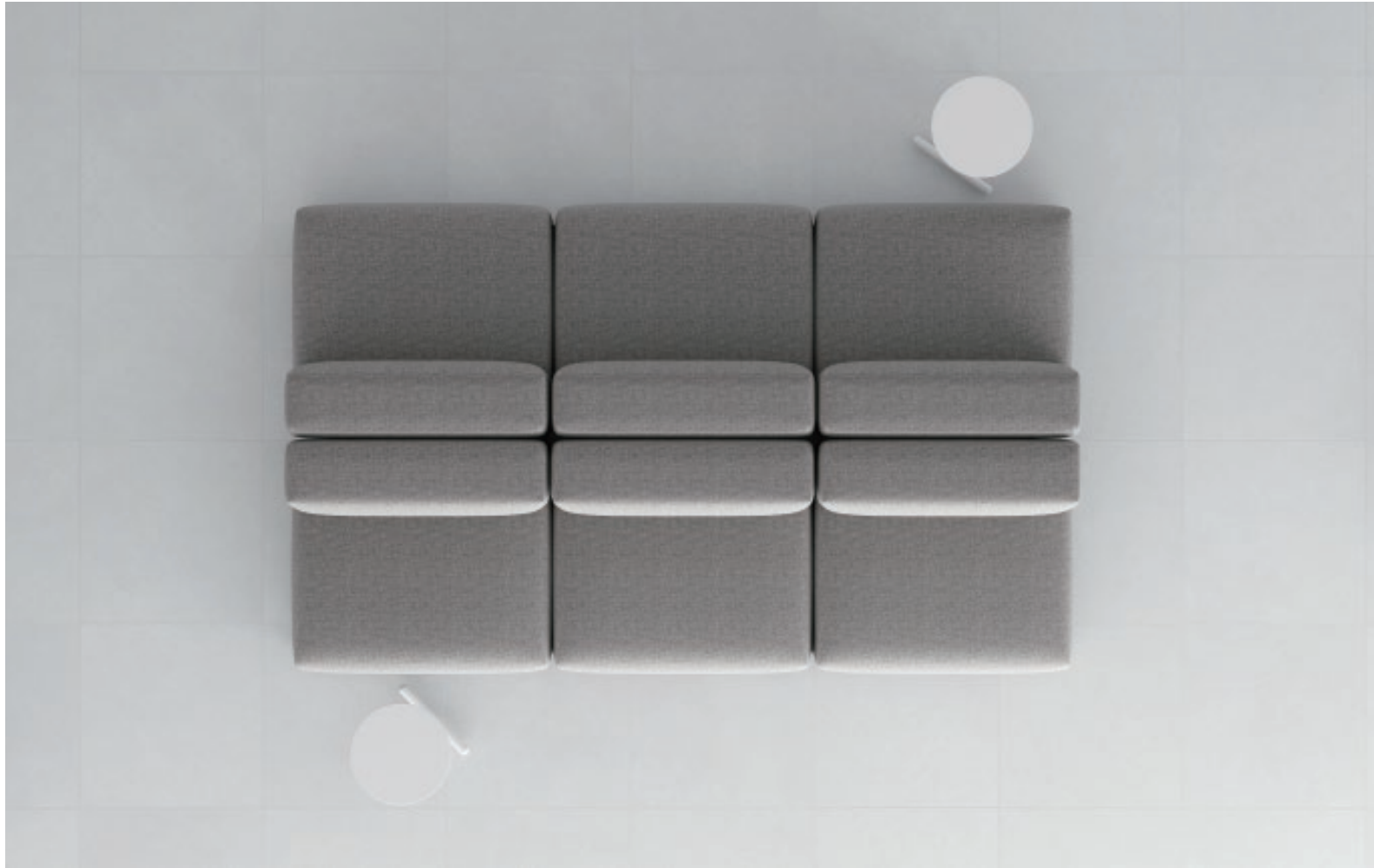

Qita sofa can be applied to a variety of spaces: lobby space, negotiation space, leisure space...

The rich combination of modules and color options can adapt to spaces of various styles and sizes, adding a different kind of vitality to the space.





AR-QIT-SO-01 W1120 D900 H720
 AR-QIT-SO-02 W1120 D900 H720
 AR-QIT-SO-03 W1000 D900 H720
 AR-QIT-SO-04 W780 D780 H400
 AR-QIT-SO-05 W1120 D1400 H720



AR-QIT-SO-06 W1120 D1400 H720
 AR-QIT-SO-07 W900 D900 H720

PRODUCT SIZE

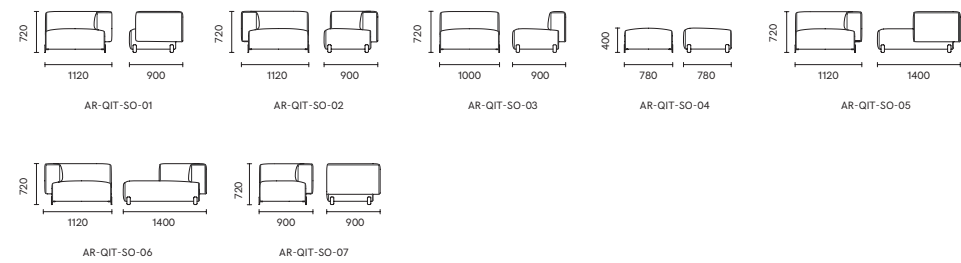

MATERIAL / MINA



MATERIAL / VICO

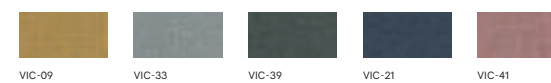



MOON

The design inspiration of the Moon sofa comes from the moon. By borrowing the profit and loss characteristics of the moon, the sofa is divided into two different periods of the lack of the moon form, combined to form a full moon, which makes the combination of the sofa more interesting.

The Moon sofa adopts round soft package radian and elegant back curve, which makes it simple and soft, and gives users more comfortable sitting experience. Based on ergonomics, the back is slightly tilted backward, the bottom of the cushion is retracted to reserve space for the feet, and the top plane design allows users to temporarily place the objects on hand to improve the utilization rate of space.

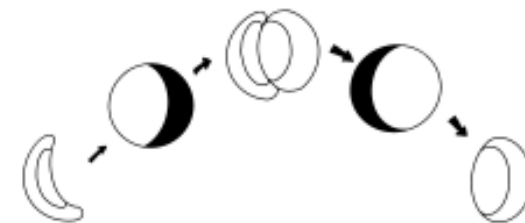









AR-MOO-SO-01
W1085 D2110 H700



AR-MOO-SO-02
W1320 D2080 H700

PRODUCT SIZE

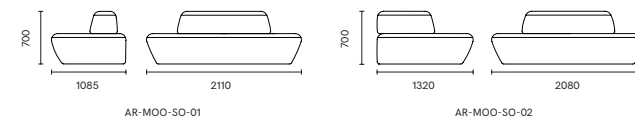

MATERIAL / YM



CUT



Cut sofa follows the design thinking of "less is more", adopts the square cutting technique to skillfully cut ordinary squares, presents a simple and powerful modeling form, and then fits the human body to adjust the detail size, and the square cutting sofa was born.

The armrest and back of the cut sofa are wrapped with the cushion, giving people a full sense of security. The incised corner of adduction and the rounded corner of edge are all carefully designed details. The throw of the back fits the human body and has a comfortable sitting feeling.

Cut sofa has a wide range of use space, in the space to meet a variety of office , leisure, entertainment, negotiation needs, can be combined with other products to meet different use space.

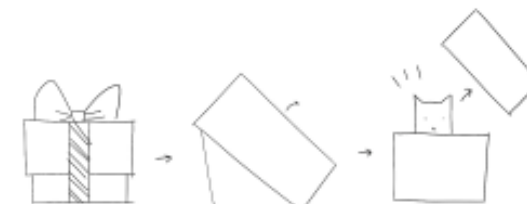









AR-CUT-SO-01
W840 D900 H750



AR-CUT-SO-02
W1410 D900 H750



AR-CUT-SO-03
W2000 D900 H750

PRODUCT SIZE

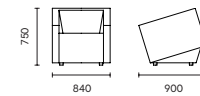

AR-CUT-SO-01

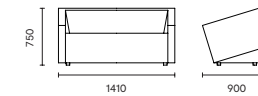

AR-CUT-SO-02

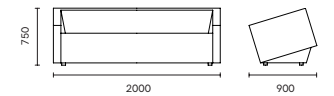

AR-CUT-SO-03

MATERIAL / VICO

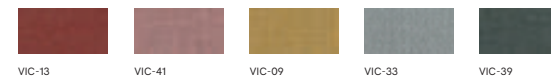

MATERIAL / LEA





LIBERTY

The Liberty sofa is inspired by the concept of replacement, DIY, and free matching, aiming to find a new breakthrough point for the most basic and most versatile sofa styles in the market

As a basic sofa, the design language of Liberty Sofa is restrained and capable. Through the data analysis of a large number of similar products on the market, we have selected the four most widely used pillows for users to choose freely, which greatly improves the adaptability of the product and satisfies users with different preferences for different types and styles. Space-such as lobby, office, leisure, negotiation, conference, reception, and extensive demand for sofas.







There are four types of Liberty sofa, single seat, double seat, three seat short, and three seat long, which can meet the needs of basic sofas in a variety of sizes.







AR-LIB-SO-01
W820 D780 H750

AR-LIB-SO-02
W1560 D780 H750

AR-LIB-SO-03
W1800 D780 H750

AR-LIB-SO-04
W2300 D780 H750



W740 D150 H375

W740 D150 H375

W740 D150 H375

W740 D150 H375

PRODUCT SIZE

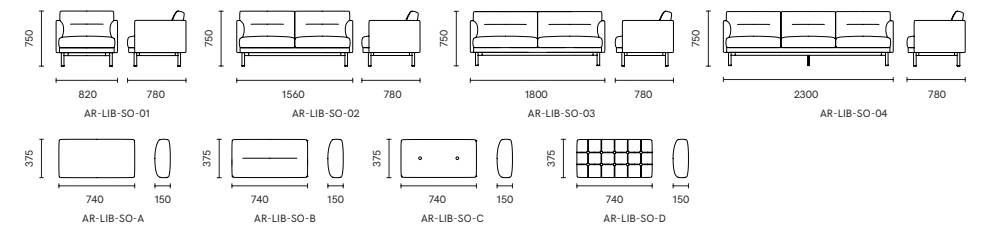

MATERIAL / VICO



MATERIAL / LEA





LINE

Inspired by Bauhaus architectural style, the left and right sofa feet adopt complete line language, from support to armrest. The designer skillfully refined the contour line of the human back into three simple lines, which are applied to the soft bag design, so that the product is comfortable to use and has both modern and classic characteristics.

The metal NC bending process of the whole pipe of Line sofa is combined with the soft bag, which has more retro characteristics. The solid wood designer of Line sofa adopts the design method of integrating armrest and leg support, which makes the point, line and surface modeling language more distinctive, and the wide armrest is more comfortable.

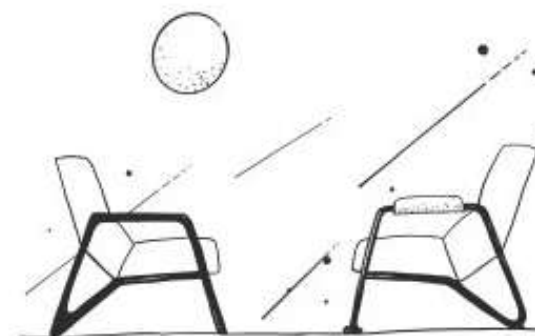



The metal style of Line sofa can be integrated into business negotiation, corridor, leisure and relaxation scenes. The wooden sofa is more applicable, not only for business space, but also for family space.









AR-LIN-SO-01
W820 D810 H780

AR-LIN-SO-02
W1270 D810 H780

AR-LIN-SO-03
W750 D790 H780

AR-LIN-SO-04
W1370 D790 H780

PRODUCT SIZE

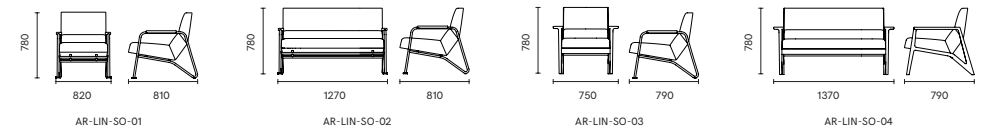

MATERIAL / SUNDAY



MATERIAL / FLOWER

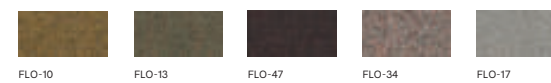



MULTI

The inspiration for the Multi sofa comes from the skyscrapers, which are full of order and rhythm. The designer will extract this design language for interpretation, showing the sofa's vibrant and energetic modern temperament. Multi sofa combines lines, surfaces and bodies in an ingenious way, revealing individuality in a low-key manner.

Multi sofa is round and soft, and adopts a double-layer enclosed structure design. The outer screen is wrapped on three sides, using the cotton thread technology to form a simple and rhythmic thousand-layer texture; the inner backrest, cushion and pillow are filled with down, soft and full, providing users with excellent wrapping and comfort.

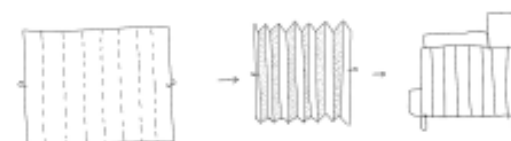



As a basic sofa with great versatility, Multi sofa can be integrated into most occasions such as office, leisure, negotiation, and civil use. The rich colors provide countless possibilities for matching.







AR-MUL-SO-01
W990 D840 H820

AR-MUL-SO-03
W1840 D840 H820

AR-MUL-SO-01A
W990 D840 H820

AR-MUL-SO-03A
W1840 D840 H820

PRODUCT SIZE

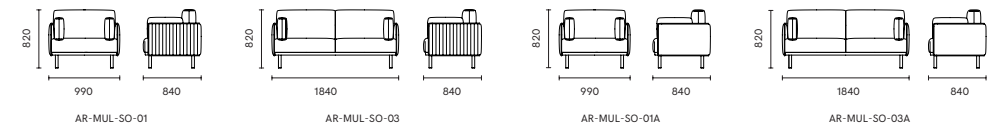

MATERIAL /MINA





SANTO

Santo highback sofa is based on Santo Modular Sofa, adding enclosed soft bag screen and writing board module, which is more suitable for the leisure and private office mode advocated by modern society.

Personal workstation can provide a quiet and thinking environment for personal work.

Three people can give two or three people private space to talk, do not affect the work of others, in order to improve work efficiency.

Video bits can help small teams work more efficiently and closely. The seats can meet the needs of many people's temporary negotiation and discussion, and the display or writing whiteboard can be hung for brainstorming.

The enclosed soft bag screen can not only protect the privacy of users, but also improve the attention and comfort of employees. The screen and the seat surface can be matched with different colors to make the office space unique.

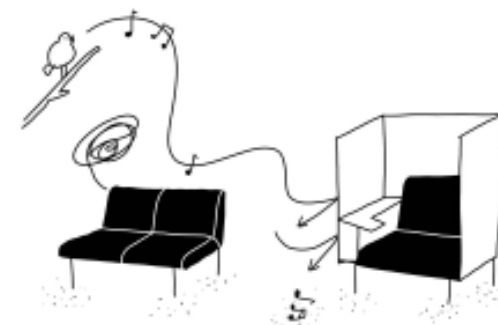





Santo series style has a total of personal workstation, surrounded by three people, surrounded by video bit three styles. It can meet the needs of personal or multi person Privacy Office, and divide a comfortable and quiet privacy area for your office space.

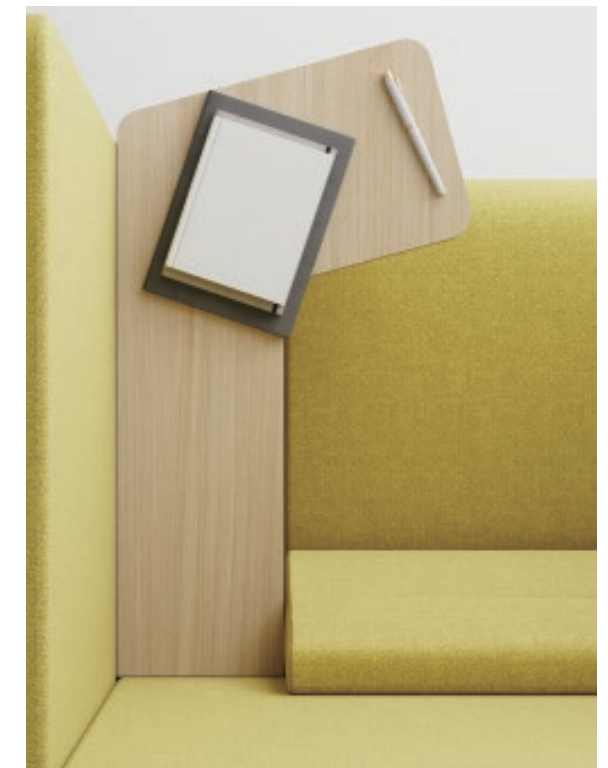

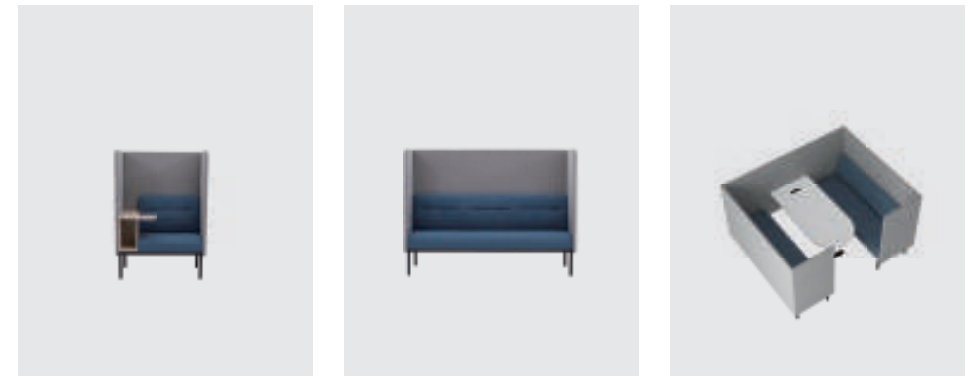

AR-SAN-HI-01
W980 D750 H1350

AR-SAN-HI-02
W1880 D685 H1350

AR-SAN-HI-03
W2220 D1870 H1350

PRODUCT SIZE

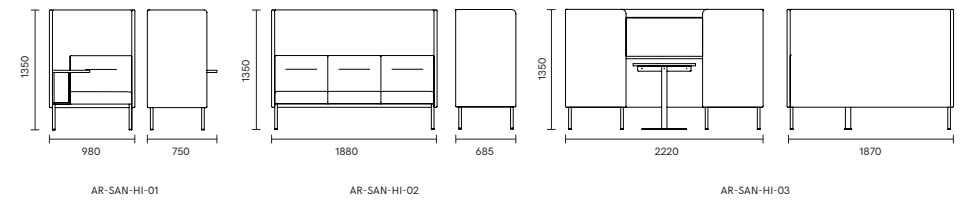

MATERIAL / LIDO



MATERIAL / SUNDAY

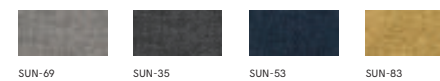

MATERIAL / VICO

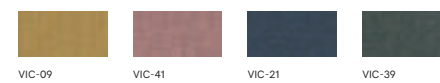



SANTO

Santo sofa is a flexible modular linear and angular seat system office furniture integrating multiple functions, providing extraordinary comfort in depth and width. The steel frame foot adopts elegant linear design and spraying technology to make it lighter and more modern. It has optional accessory modules such as backplane, bar and table board to meet the use needs of a variety of spaces.

Santo provides more than 20 modules, providing more choices for customers' personalized office, and meeting the needs of any space such as rest, meeting, waiting and so on.

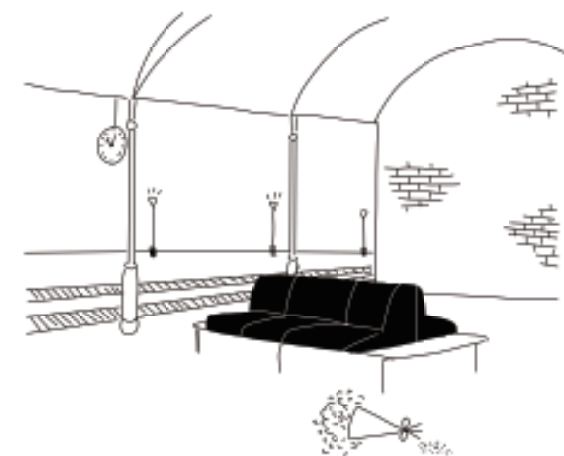











PRODUCT SIZE

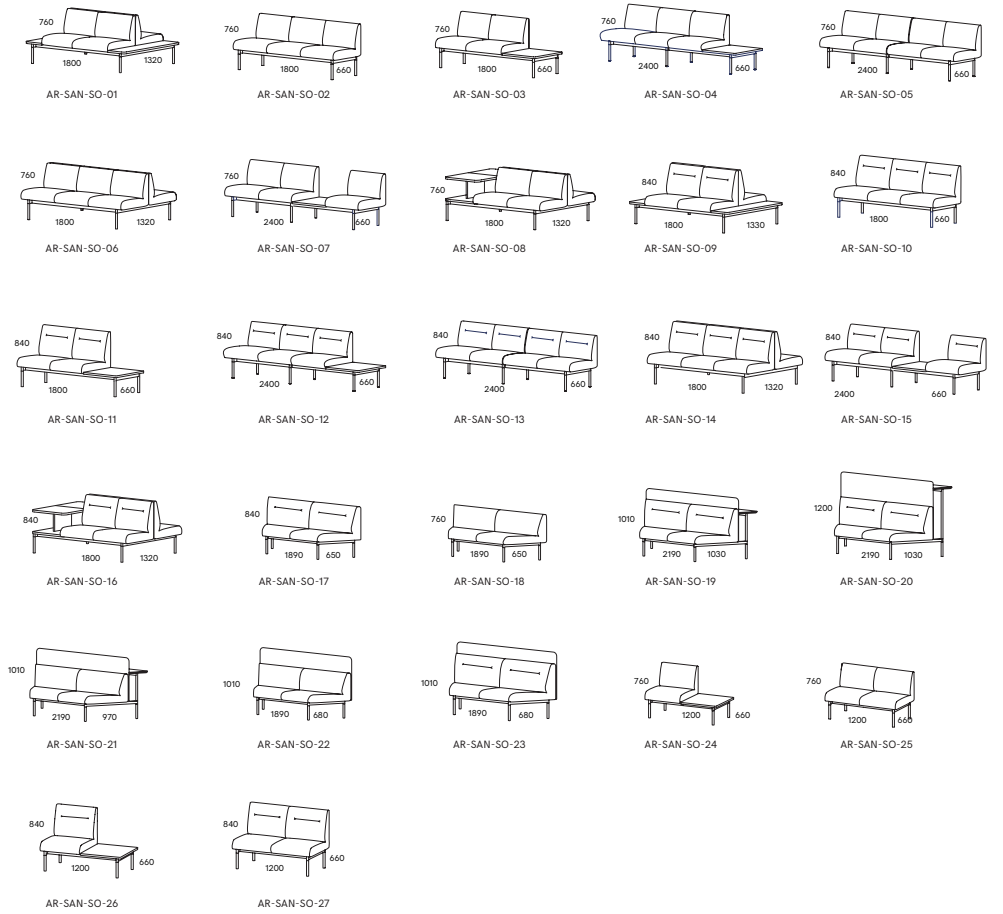

MATERIAL / LIDO



MATERIAL / SUNDAY

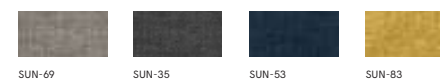

SHEEP

The Sheep short back sofa continues the design language of the sheep high back sofa horn. The embossed enclosing structure vividly shows the characteristics of the horns. At the same time, the inclined armrests fit the angle of the arm placement, bringing a comfortable leaning experience.

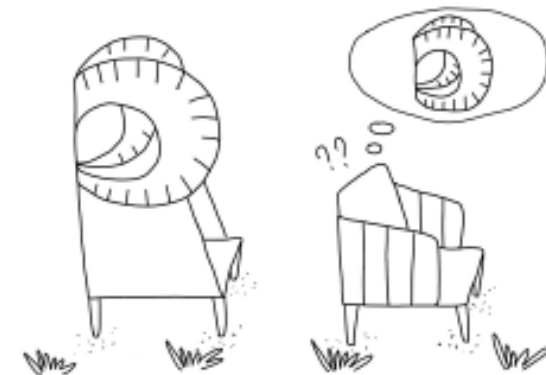







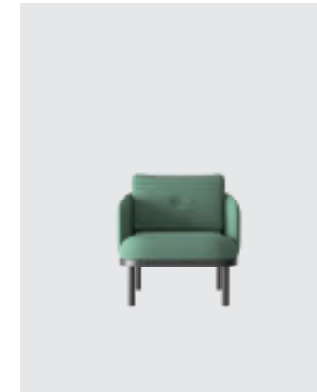

AR-SHE-SO-04
W740 D750 H800



AR-SHE-SO-05
W1520 D750 H800

PRODUCT SIZE

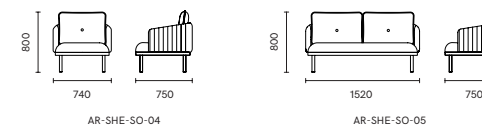

MATERIAL / MINA





SHEEP

Sheep sofa is inspired by sheep's soft body. The headrest part is embossed with fabric, which provides comfortable wrapping feeling and echoes the fluffy and soft texture of wool. In our actual use process, it can also provide an efficient and private negotiation space.

Sheep sofas are available in three fabrics: Cashmere/leather/conventional fabrics and color matching of color systems also provide customers with more choices.

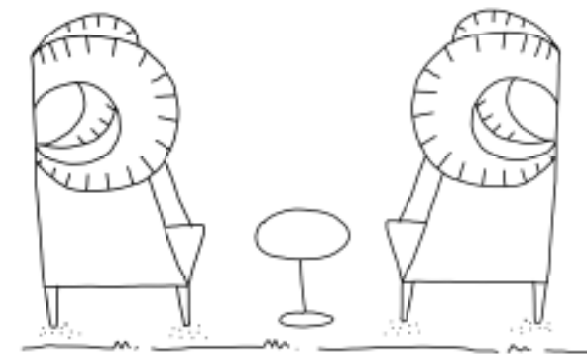



Sheep sofas are available in single and double sizes. It is mainly used for privacy office and customer reception function blocks in the space. The soft body not only provides comfort, but also provides sound insulation. In order to meet the needs of efficient office, it can be equipped with writing board table.







AR-SHE-SO-01
W930 D760 H1260



AR-SHE-SO-02
W1540 D760 H1260



AR-SHE-SO-03
W400 D300 H650

PRODUCT SIZE

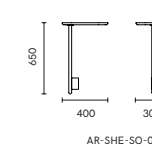
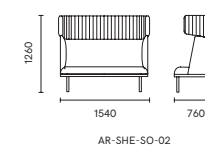
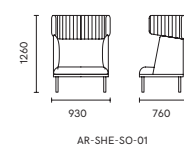

MATERIAL / MINA





SQUARE

The Square sofa adopts a minimalist design style. In terms of modeling, the sofa adopts the design of cube sugar, which is in contrast with the external pipes. The lines of the pipe and the shape of the soft bag make people feel that this is a business sofa with very good design. The length of the cube square sofa can be increased from single to three. The spliced sofa group has undoubtedly created a good place to rest for the busy office. Cube sugar sofa can also be used in public space, negotiation space, business space and other places. Unique appearance, human design and excellent use experience are the perfect choice for mature and human workplace.









AR-SQU-SO-01
W1010 D800 H700



AR-SQU-SO-02
W1650 D810 H700



AR-SQU-SO-03
W2000 D810 H700

PRODUCT SIZE

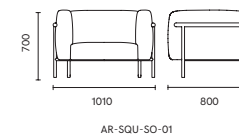

AR-SQU-SO-01

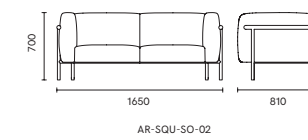

AR-SQU-SO-02

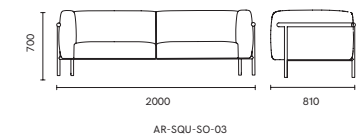

AR-SQU-SO-03

MATERIAL / LEA



LEA-02

LEA-04

MATERIAL / MINA



MIN-02

MIN-16

MIN-20

MIN-21



MELLO

Inspired from jelly sweets, the shape of Mello is round, organic and elegant. Touched round and smooth, the shapes of back and armrests serve an excellent seating experience as well. With the use of unique fabric, Mello series shows the brilliant temperament, which is born to be the bright points wherever it's served.

Mello series consists of 1-seaters,2-seats,3-seaters, which make it possible to fit any needs of lounge while lighting the spaces.

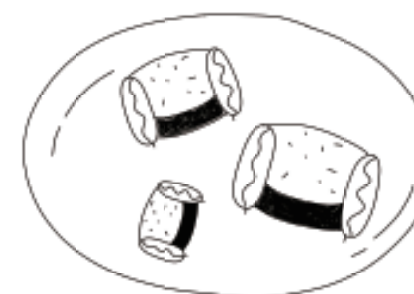



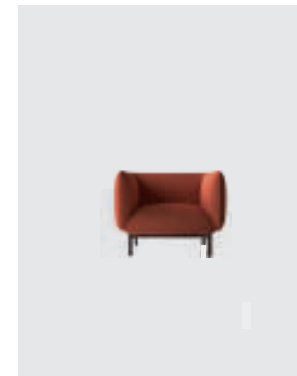

AR-MEL-SO-01
W960 D840 H720



AR-MEL-SO-02
W1560 D840 H720



AR-MEL-SO-03
W1960 D840 H720

PRODUCT SIZE

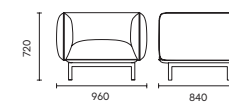

AR-MEL-SO-01

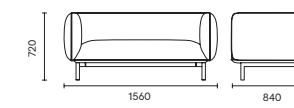

AR-MEL-SO-02

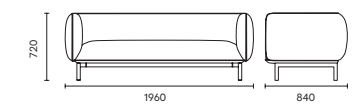

AR-MEL-SO-03

MATERIAL / MINA



MATERIAL / FLOWER

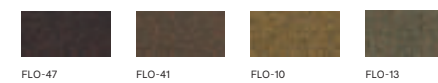



CITY

Buildings make it ordered for a city as well as sofa system elements. City series provides different single elements to group that you can get any combination you want to fit your space perfectly. Like a "city" in your space, every seating element is invested with their function and lies there orderly. City series consists four parts from a sofa: seat element, armrest element, back element and pouf element, that you can combine them as you like to fit any space if you require.

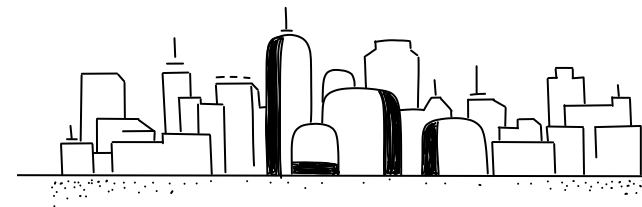



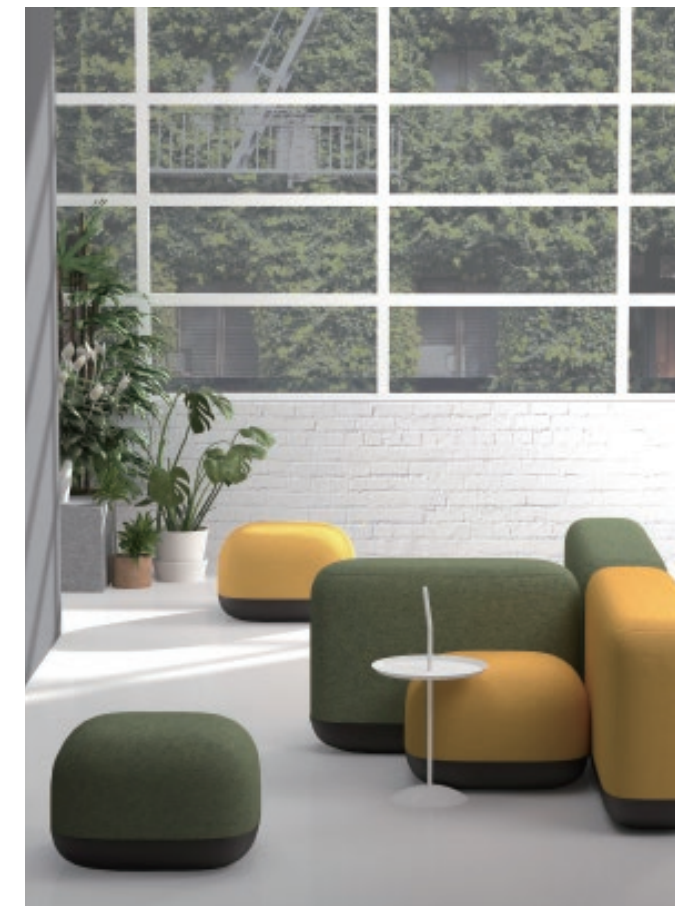





AR-CIT-SO-01
W620 D620 H430



AR-CIT-SO-02
W1360 D620 H430

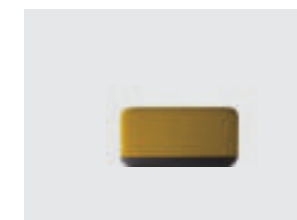

AR-CIT-SO-03
W1360 D350 H660

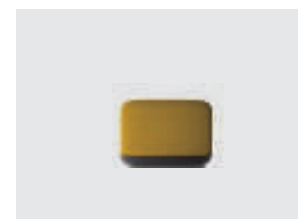

AR-CIT-SO-04
W950 D350 H660



AR-CIT-SO-05
W1200 D350 H660

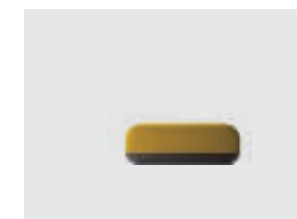

AR-CIT-SO-06
W1200 D620 H430

PRODUCT SIZE

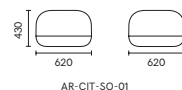

AR-CIT-SO-01

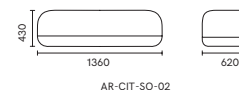

AR-CIT-SO-02

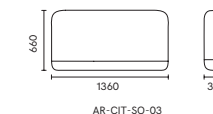

AR-CIT-SO-03



AR-CIT-SO-04

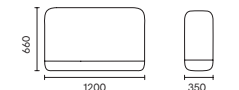

AR-CIT-SO-05

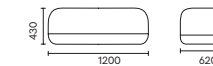

AR-CIT-SO-06

MATERIAL / SUNDAY

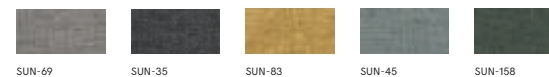

SUN-69

SUN-35

SUN-83

SUN-45

SUN-158

MATERIAL / YM

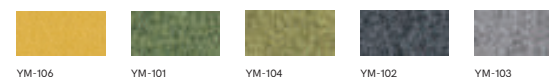

YM-106

YM-101

YM-104

YM-102

YM-103



KAS

Kas series, is a modular system of sofa elements combining short and long elements, which meets different needs for different areas such as waiting, resting and meeting by combining these elements. With lines as smooth and elegant as a signature, Kas series can light the spaces while providing excellent sitting experience.

To fit the new trend of office behavior, Kas series provides 2 more high-back versions, 1-seater and 2-seater, which meets the needs of privacy for individual office.

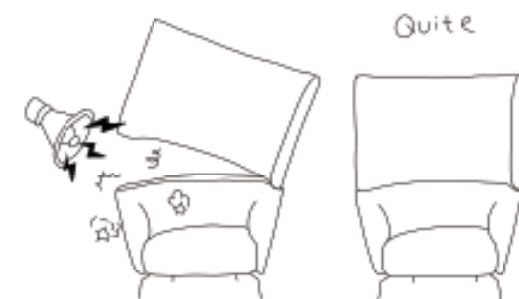







Kas high-back version can serve as single sofa or face-to-face organizing principle for the needs for resting and meeting.



AR-KAS-SO-01 AR-KAS-SO-02 AR-KAS-SO-03 AR-KAS-SO-04 AR-KAS-SO-05 AR-KAS-SO-06
 W1600 D780 H1340 W1600 D780 H660 W1000 D780 H1340 W1000 D780 H660 W1460 D760 H660 W1460 D760 H660



AR-KAS-SO-07 AR-KAS-SO-08 AR-KAS-SO-09 AR-KAS-SO-10 AR-KAS-SO-11
 W770 D760 H660 W770 D760 H660 W1300 D760 H660 W1040 D760 H660 W1090 D1100 H660

PRODUCT SIZE

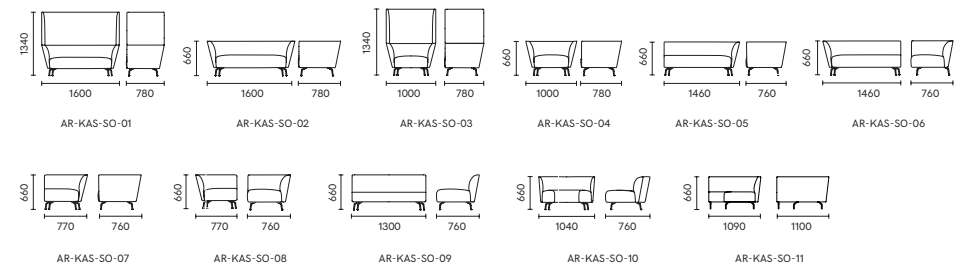

MATERIAL / LIDO



MATERIAL / SUNDAY



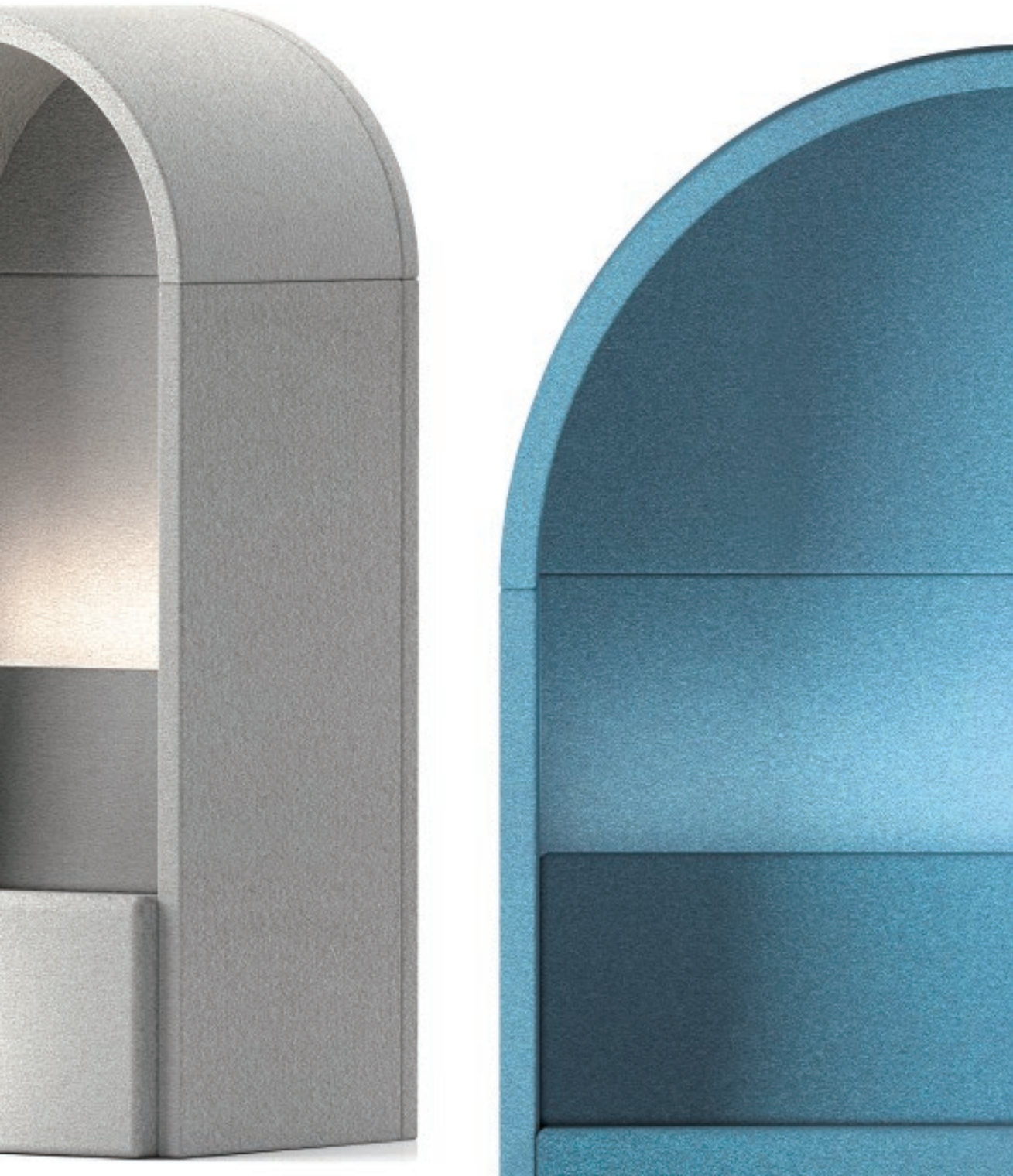

ROMA

The design of Roma series combines the elements of archway and pillar from Roma architecture style, which are mixed into the modern office behavior, to serve a useful lounge seating series with a sense of form. Roma series consists of 1-seaters, 2-seaters and bar island to fit different spaces and needs. Power supply system and LED lighting are available for customers to get a convenient and comfortable environment.





The sofa provides single, double and bar island styles for customers to choose, which meets different space sizes and uses of office space





AR-ROM-SO-01
W920 D760 H1900



AR-ROM-SO-02
W1450 D760 H1900



AR-ROM-SO-03
W1900 D910 H2110

PRODUCT SIZE

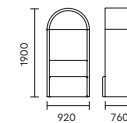

AR-ROM-SO-01

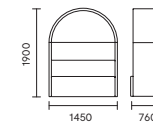

AR-ROM-SO-02

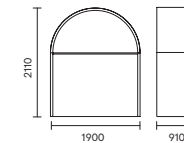

AR-ROM-SO-03

MATERIAL / YM

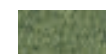

YM-101



YM-104



YM-102



YM-115



BREAD

The inspiration of Bread armchair comes from the soft modeling of bread. The overhanging backrest armrest makes the product appear light and delicate, presenting rich layers from all angles; the rounded corner treatment makes the geometric sofa more soft and comfortable; the color matching of the backrest and the cushion, and the difference between the different modules Color matching also provides a richer and more interesting space for users to play.

The tilted armrest of the Bread armchair perfectly fits the human body; the radian in front of the seat is designed to look like a smile, breaking the external square hard shape, giving users a sense of affinity.











AR-BRE-AR-01
W630 D640 H730

PRODUCT SIZE

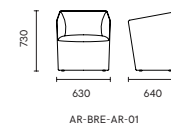

MATERIAL / SUNDAY

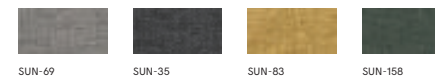

MATERIAL / YM

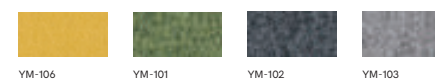



UP

The inspiration of the Up armchair is derived from the traditional Chinese dress element - vertical collar.

By refining the external contour of the collar, the designer has formed the shape curve of the Up armchair. Meanwhile, the pull wire design of the waist improves the product's sense of modeling, and the overall surrounding sense of the back gives the user a comfortable experience.

The Up armchair adopts foaming technology, with soft edge turning, which gives users a thick sitting feeling and comfortable arm support.

Up armchair is made of cashmere and fabric. Users can choose the fabric according to their needs.

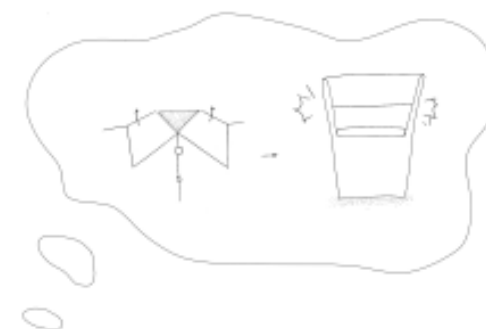







There are two styles of UP armchair : basic chair and automatic return chair.

The basic chair is equipped with wear-resistant foot pad, which is easy to move; The automatic return chair can automatically turn and return when the user gets up and leaves.

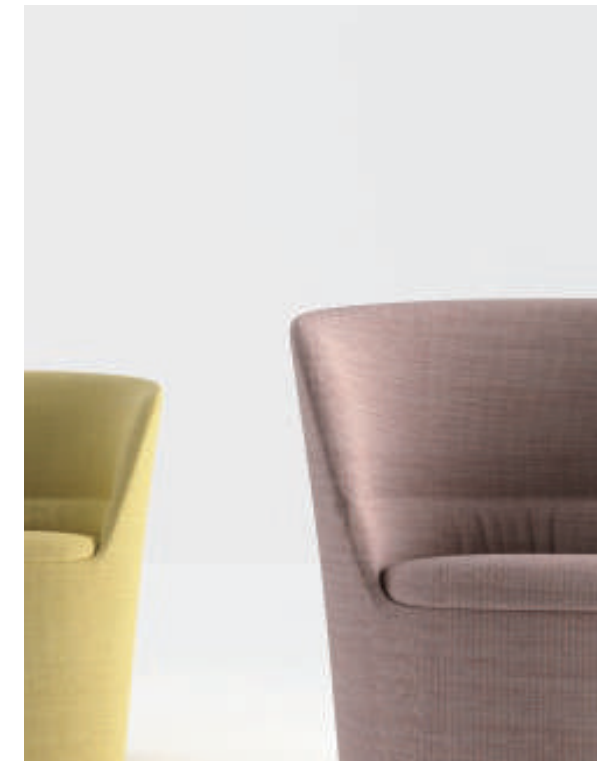



AR-UP-AR-01
W650 D610 H710



AR-UP-AR-02
W650 D610 H720

PRODUCT SIZE

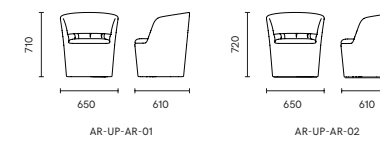

MATERIAL / VICO



MATERIAL / YM

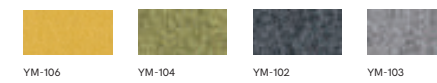

MATERIAL / FLOWER





FLY SIDE

The Fly side chair series is inspired by the elegant posture of the swan and the graceful curve of the neck.

In the extended Fly side chair series, the designer slightly arches the chair surface and back under the premise of extracting the elegant curve of the swan to create a chair with an excellent wrapping shape.

The Fly side chair series has a complete ecosystem, from side chairs to bar chairs, there are dozens of tripods and functional accessories to choose from, which greatly meets the requirements of various training spaces, meeting spaces, and leisure spaces. demand.









Fly side chair's back is slightly wrapped inward, which can provide a good wrapping feeling for the back; for comfortable sitting feeling, the inclination of the seat surface has been repeatedly deliberated; the slightly outward leaning side feet are convenient for stacking and storage, and can effectively use the space.







Fly side chair is a product designed from the training space. Due to the choice of different tripod configurations, it is not only applicable to the training space, but also applicable to other environmental spaces: tea space, negotiation space, education space, library, etc. Become a public area and create elegant configuration.





AR-FLY-SI-01 W540 D530 H760
 AR-FLY-SI-02 W540 D530 H740
 AR-FLY-SI-03 W540 D630 H740
 AR-FLY-SI-04 W480 D520 H760
 AR-FLY-SI-05 W495 D355 H280
 AR-FLY-SI-06 W460 D520 H760



AR-FLY-SI-07 W660 D800 H760
 AR-FLY-SI-08 W460 D540 H760
 AR-FLY-SI-09 W510 D250 H280
 AR-FLY-ST-01 W530 D530 H1040
 AR-FLY-ST-02 W530 D520 H1050
 AR-FLY-ST-03 W540 D530 H1060

PRODUCT SIZE

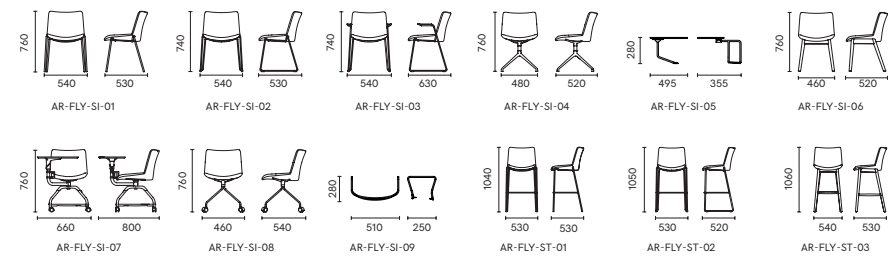

MATERIAL / YM

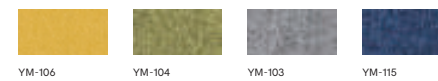

MATERIAL / SUNDAY

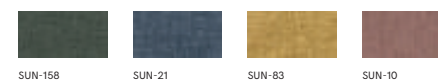

MATERIAL / LEA





FLY

The intention of the design of the Fly chair is to provide users with a good sense of package. Designers also hope that this series of products can have elegant curves like swan wings. Whether visually or in use, it can bring good experience to the users.

There are 4 Fly series: High back leisure chair, low back leisure chair, chair style, foot pedal; The product has a wide range of applications, including office and leisure areas, dining areas, reading areas, reception areas, etc. The product's adaptation space is more diverse. At the same time, multi-color system also increases more possibilities for products.

Fly chairs are available in wood feet, four-star feet and steel frames to meet the space needs of different users.







The Fly chair adopts an integrated foaming process, and the backrest is slightly wrapped inward, which can provide a good wrapping feeling for the back. The armrest is folded outward to fit the curve of the human hand and give support.

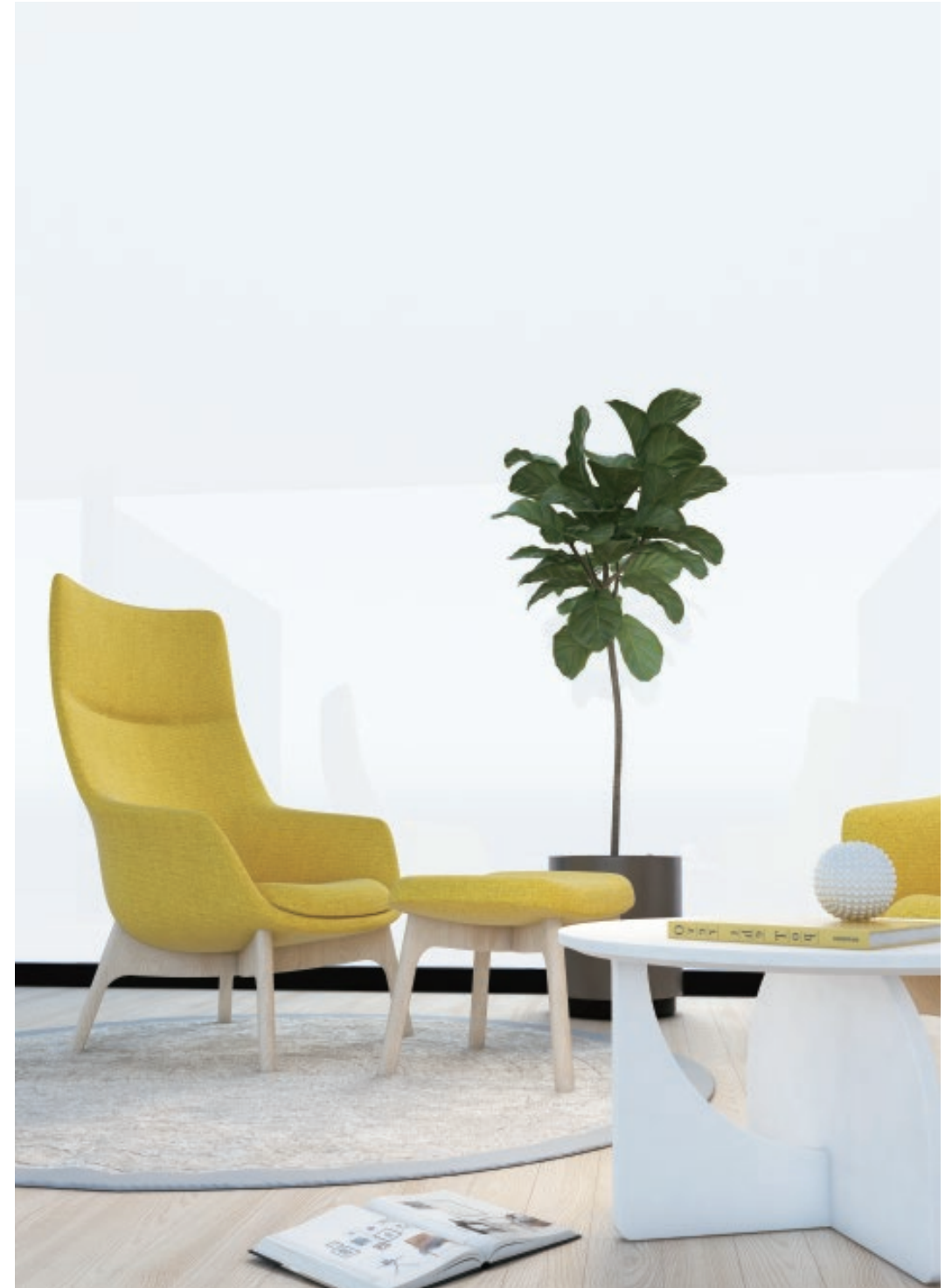



The product has a wide range of applications, including office and leisure areas, dining areas, reading areas, reception areas, etc. The product's adaptation space is more diverse. At the same time, multi-color system also increases more possibilities for products.

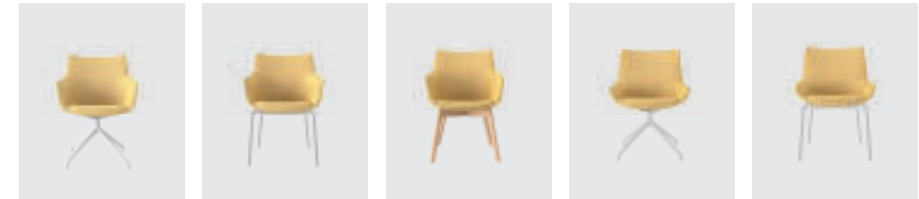

AR-FLY-CH-01	AR-FLY-CH-02	AR-FLY-CH-03	AR-FLY-CH-04	AR-FLY-CH-05
W610 D590 H810	W610 D590 H800	W610 D590 H800	W560 D580 H810	W560 D580 H800



AR-FLY-CH-06	AR-FLY-CH-07	AR-FLY-CH-08	AR-FLY-CH-09
W560 D580 H800	W770 D720 H820	W770 D770 H1100	W540 D410 H390

PRODUCT SIZE

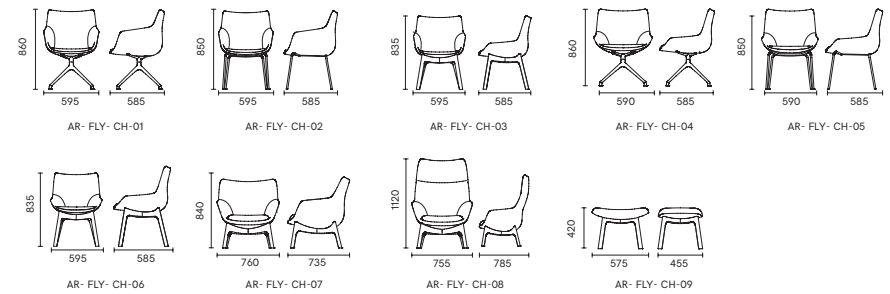

MATERIAL / VICO

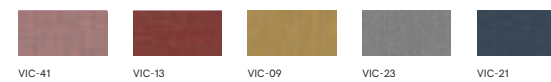

MATERIAL / FLOWER





ET

ET chair was inspired by aliens in science fiction films. The unfolding of the foot stand adds interest to this product, which is different from other leisure chairs. In order to meet the user's good use experience, ET Chair is treated in strict accordance with ergonomics. After repeated tests, every user can have the most comfortable sitting feeling. In terms of fabric color, ET also has rich choices to meet the needs of various spaces. The versatile chair is suitable for various public spaces, such as libraries or offices, waiting rooms, restrooms, restaurants and hotels. It is a very useful product.

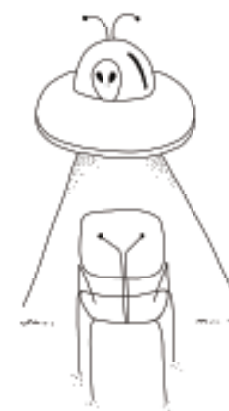

The semicircular metal fittings on the steel tube of the backrest look like ET eyes. The curvature of the backrest is more like the face shape of an ET.







AR-ET-CH-01
W520 D560 H790

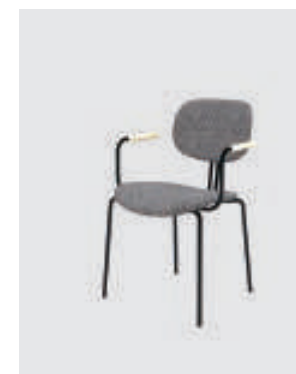

AR-ET-CH-02
W530 D560 H790

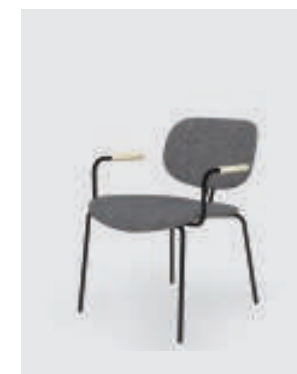

AR-ET-CH-03
W620 D610 H695

PRODUCT SIZE

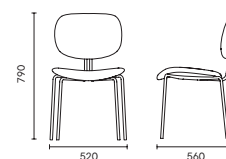

AR-ET-CH-01

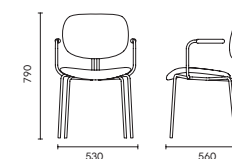

AR-ET-CH-02

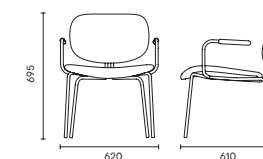

AR-ET-CH-03

MATERIAL / SUNDAY

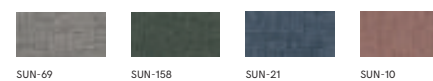

SUN-69 SUN-158 SUN-21 SUN-10

MATERIAL / VICO

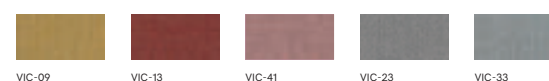

VIC-09 VIC-13 VIC-41 VIC-23 VIC-33

MATERIAL / YM



YM-104 YM-103 YM-115



ALGER

Inspired by the classic furniture of the 1950s—the Womb Chair, the designer designed the Leisure Chair-ALGER by remodelling the curve of the Womb Chair. The upward curving element at sides serves the function of armrest, which makes the design simple and polished. Based on the process design of the car seat, designer inlaid soft packs on the seat and back of the chair, makes ALGER fit the curve of human body and more ergonomic to satisfy different needs of users. There are two models for ALGER, first model is with headrest, it provides privacy in office environments, gives the user sufficient private space. Second model is without headrest, it has higher flexibility to match with different environments and also keeps its aesthetic and utility.







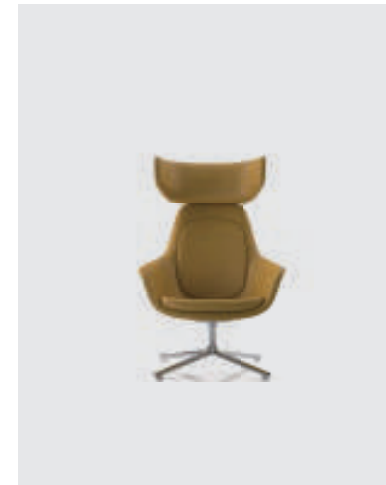

AR-ALG-LO-01
W760 D800 H1170

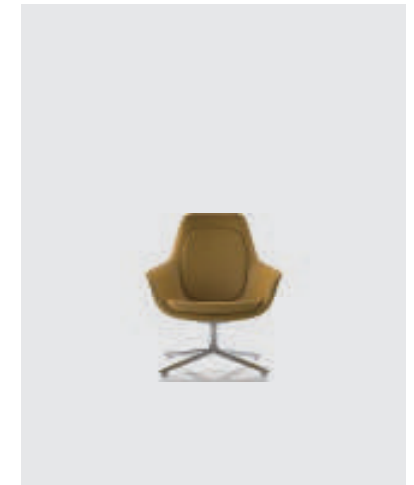

AR-ALG-LO-02
W780 D800 H930

PRODUCT SIZE

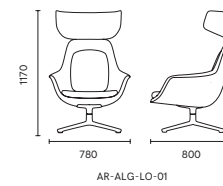

AR-ALG-LO-01

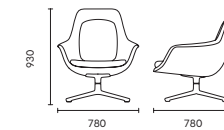

AR-ALG-LO-02

MATERIAL / YM

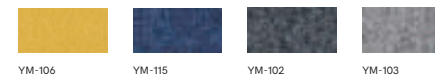

YM-106

YM-115

YM-102

YM-103

MATERIAL / LEA



LEA-02

LEA-04

LEA-06



SYS

SYS series is composed of chairs, armchairs and stools with different options based on metal or wood, which is a chair system collection on Archini product lines. Inspired by the texture of shell, designer reflects this feeling of texture on SYS series with the technique of embossing, which touches smooth and stereo. Every line around the chair is carefully adjust for hundreds times to fit the shape of human's back curve, which serves an excellent seating experience for everyone. SYS chair consists of two versions, with-arms and no-arms, to meet different needs of customers. What's more, different bases can perfectly fit wherever you want..









SYS lounge chair provides the bigger dimension and the thicker soft, which make it possible for people to sit more comfortably or even sleep on it







SYS bar stool shows an elegant curve, which can be served in coffee area, bar or meeting area. The soft seating experience can comfort everyone while resting.



AR-SYS-CH-01 W730 D740 H820	AR-SYS-CH-02 W600 D630 H820	AR-SYS-CH-03 W570 D610 H820	AR-SYS-CH-04 W600 D630 H820	AR-SYS-CH-05 W570 D610 H820
--------------------------------	--------------------------------	--------------------------------	--------------------------------	--------------------------------

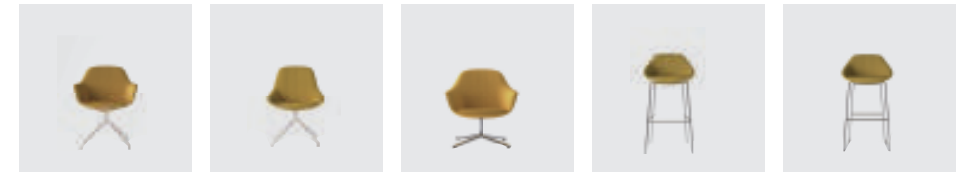

AR-SYS-CH-06 W600 D630 H820	AR-SYS-CH-07 W570 D610 H820	AR-SYS-CH-08 W730 D740 H840	AR-SYS-CH-09 W520 D510 H880/980	AR-SYS-CH-10 W520 D510 H870/970
--------------------------------	--------------------------------	--------------------------------	------------------------------------	------------------------------------

PRODUCT SIZE

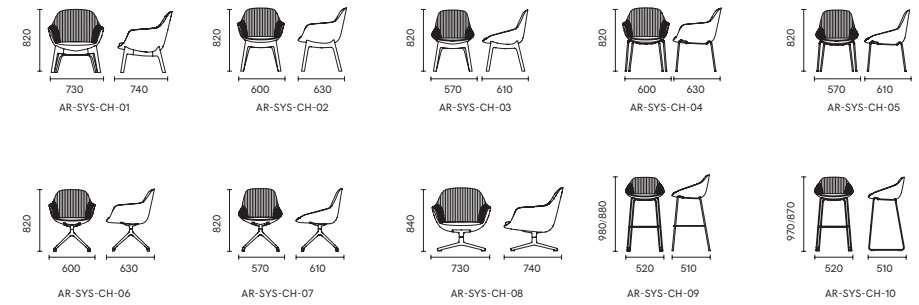

MATERIAL / HY

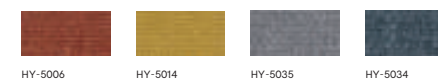



BEAN

Bean bar stool is equipped with different colors of fabric, and equipped with two different materials of tripod, which can meet the needs of different spaces.

Bean bar stool is designed with two kinds of tripods, which can be matched with different tripods according to different use needs, and the use space is wide. The round head is used to deal with the return foot and the wooden foot, and the cylindrical foot continues the design language of broad bean. Bean bar stool is designed with two kinds of tripods, which can be matched with different tripods according to different use needs, and the use space is wide. The round head is used to deal with the return foot and the wooden foot, and the cylindrical foot continues the design language of broad bean.





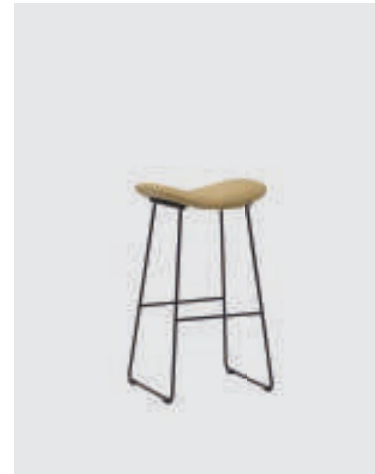

AR-BEA-ST-01
W460 D380 H780

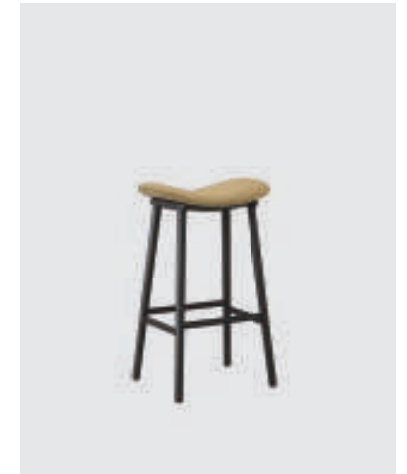

AR-BEA-ST-02
W460 D380 H780

PRODUCT SIZE

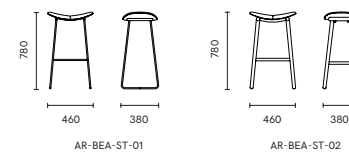

MATERIAL / SUNDAY

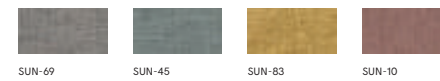

MATERIAL / VICO



SHELL



The inspiration of the Shell bar chair comes from the stripe element of the shell. The designer refined the shell thread as the design element and used the modern embossing process to greatly improve the utilization rate of the medium pressure fabric. The product is environmentally friendly. At the same time, customers can customize the fabric color matching of the seat surface. The seat surface is made of a whole sponge, which is elastic and comfortable. The steel frame of the four legged Shell bar chair has stable structure and light overall weight, which is convenient for flexible use in space.

The Shell bar chair of the column type adopts a lifting chassis with adjustable height, which can be used in use scenarios with different heights. The pedals are processed with rounded corners to avoid metal hooking and ensure product safety.

Shell bar chair can be applied to a variety of spaces, such as leisure space, training space, video space, fast office area, tea space, etc. in the space, it can meet the needs of office, leisure and entertainment, match with rich fabric selection, and inject vitality into the office space.

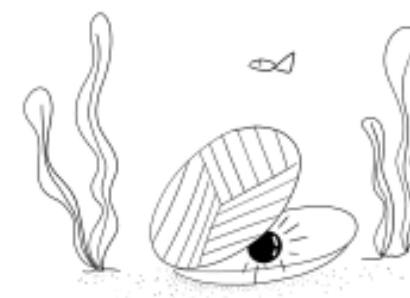





AR-SHE-ST-01
W460 D460 H765



AR-SHE-ST-02
W425 D380 H800

PRODUCT SIZE

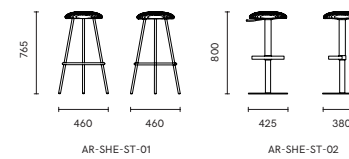

MATERIAL / HY

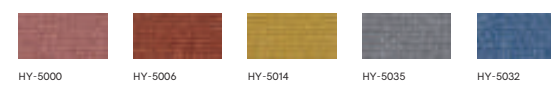



PIPE

The shape of the sitting pier is inspired by the pipe. The "pipe" is endowed with richer connotation by the way of the integrated wrappings and patchwork of soft bags. Its nifty and lovely appearance gives users a close feeling. In space, it embellishes colors and enlivens the atmosphere.

The pipe pier is a multifunctional sitting pier, which integrates the functions of seat, writing desk and storage. The extended small table top can be used for both personal belongings and temporary office. It also allows people to lean on and relax when they are tired.

The multifunctional pipe pouf has an affinity, and its comfortable sitting feeling and rich functions make it suitable for leisure areas, tea areas and other areas.





The gap between the sitting pier and the backrest can be used for accommodating books and magazines. In public space, it provides people with a more convenient and comfortable reading mode.





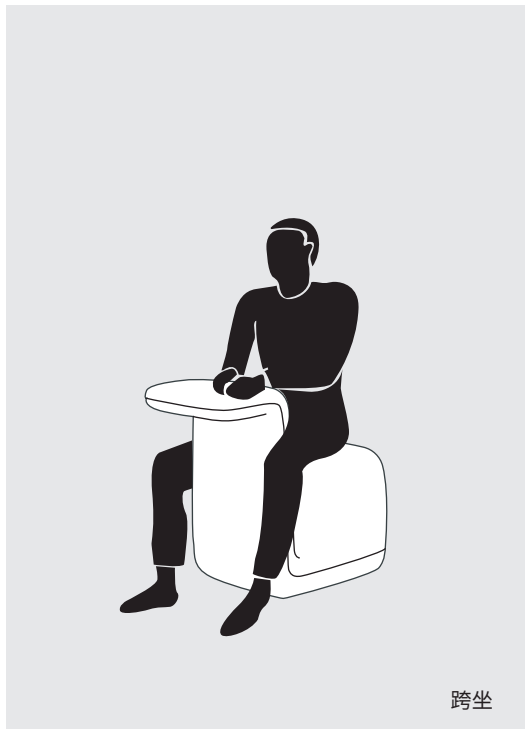
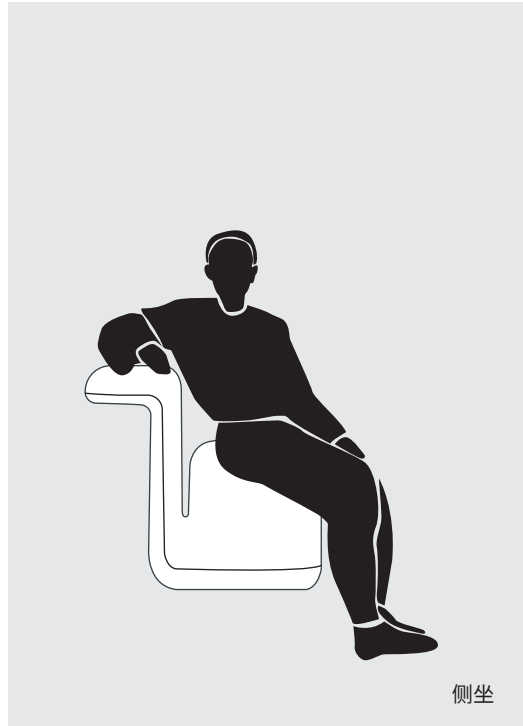
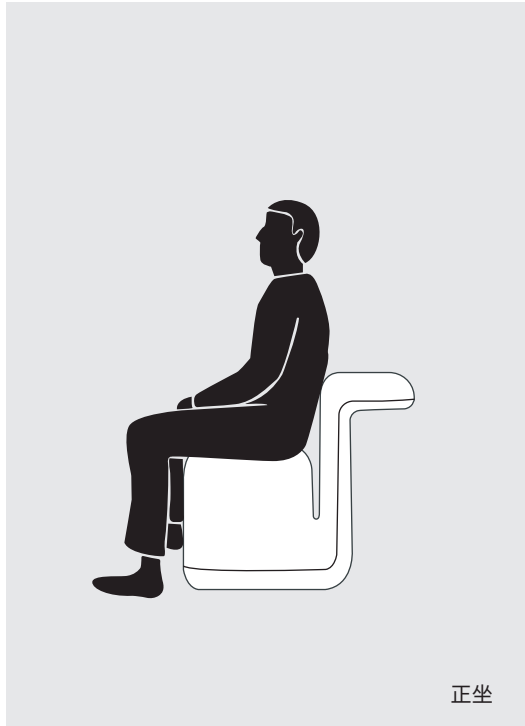

AR-PIP-PO
W420 D700 H590

PRODUCT SIZE

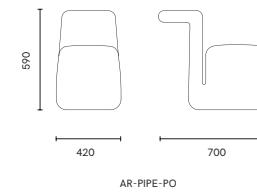

MATERIAL / SUNDAY



MATERIAL / YM

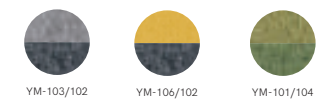

MATERIAL / FLOWER





BAG

The inspiration for the leather bag pier comes from women's backpacks. Designers apply fashion design elements to furniture to form unique visual feelings. The overall appearance of the leather bag is hard, but the seat surface slightly bulges. It shows a fashionable and playful appearance and also reminds people of the shape of a vintage leather bag.

There are 4 specifications for the leather bag pier. Different sizes can be adapted to different uses and environments. It can be scattered freely in the office space or placed in groups of three or two to embellish the space and add interesting atmosphere. In addition, XL style is also reliable and flexible for wall use.

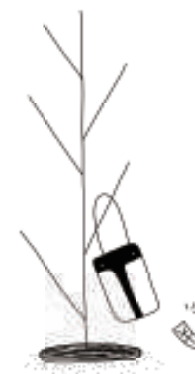

The double-color patchwork technology is adopted for the leather bag pier. There is a contrast between colors. Modern technology is used to strengthen the design details so as to enhance the texture of the product.





AR-BAG-PO-S
W380 D380 H430



AR-BAG-PO-M
W580 D580 H430



AR-BAG-PO-L
W785 D785 H430



AR-BAG-PO-XL
W1240 D520 H430

PRODUCT SIZE

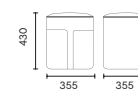

AR-BAG-PO-S



AR-BAG-PO-M

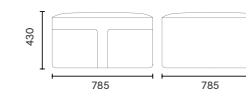

AR-BAG-PO-L



AR-BAG-PO-XL

MATERIAL / SUNDAY



MATERIAL / YM

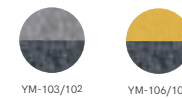



BUONO

The Buono Series, inspired by minimalist modern architecture, deliberately deduces concise lines in modern architecture. Use hard and elegant tangents to form a group of simple and highly constructed stools. Buono series, can be scattered at will, can also be placed in groups of three or two, thereby ornament space, configuring of a variety of office space.







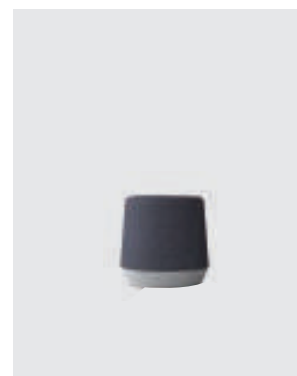

AR-BUO-PO-S
Φ440 H430



AR-BUO-PO-M
Φ680 H390



AR-BUO-PO-L
Φ1080 H360

PRODUCT SIZE

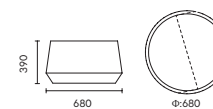
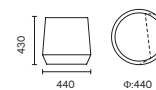

AR-BUO-PO-M

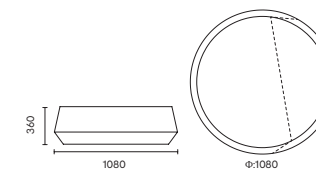

AR-BUO-PO-L

推荐面料

MATERIAL / SUNDAY

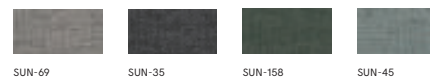

SUN-69

SUN-35

SUN-158

SUN-45

MATERIAL / YM

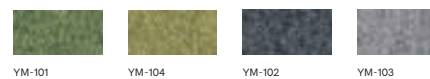

YM-101

YM-104

YM-102

YM-103



MELLO

As a series of products of Milo sofa, Milo tea table follows its unique form of tripod. The tripod and countertop of Milo tea table have a cantilever design to create a unique floating and lightness feeling; The black-and-white rhyolite board is steady and elegant, and the cutting edge on the side shows exquisite technology; Square or round countertops with staggered underframes provide more possibilities for combination.

The Milo tea table is connected with the table through an easily installed suction cup. The disassembly and assembly of the tripod is also very simple, which can be packaged and transported flat.

From the two aspects of temperament and function, Milo tea table can easily integrate into all kinds of office space to improve the style of the space.

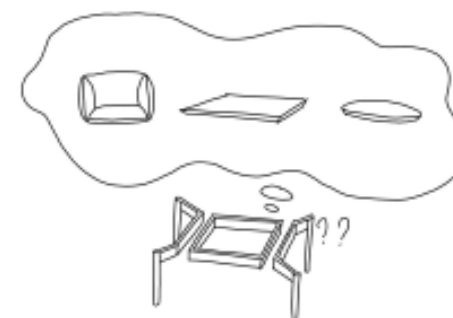



AR-MEL-TB-01
W600 D600 H265



AR-MEL-TB-02
W600 D600 H400



AR-MEL-TB-03
W1200 D600 H400

PRODUCT SIZE

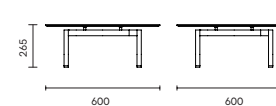

AR-MEL-TB-01

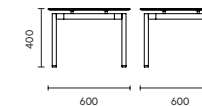

AR-MEL-TB-02

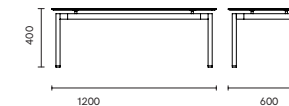

AR-MEL-TB-03

COLOR OPTIONS



雪山石

莎罗兰



COLLAR

Tang costume is a modern traditional Chinese costume. It draws on western tailoring concepts and Chinese cultural elements, and shows the characteristics of openness and tolerance of Chinese culture and the upward spiritual outlook of Chinese in the new era. The inspiration for the collar series comes from this traditional Chinese costume-Tang costume.

Collar series combines the characteristics of Tang costume: Standing collar, double breasted collar and buckles add Chinese style and western style elements to the collar series. In addition, the collar table body adopts steel plate bending process and cloth treatment to meet the needs of modern industrial production.









Apart from making different designs on the appearance characteristics of this product, the designer has also considered the need for efficient office work, and has set up a USB charging port on the front body for users to use, thus more embodying the humanized design concept.





AR-COL-TB-01
W1000 D1000 H730



AR-COL-TB-02
W800 D800 H730



AR-COL-TB-03
W450 D450 H430



AR-COL-TB-04
W800 D800 H285

PRODUCT SIZE

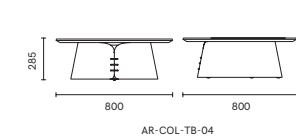
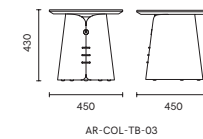
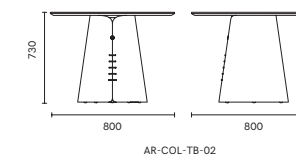
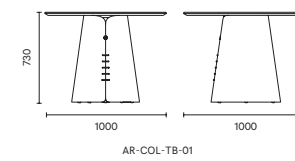

MATERIAL / HY

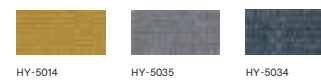



PLANK

The inspiration for the panel tea table comes from the concept of the harmony of Yin and Yang in Tai Chi.

The design of the product fully draws on the wisdom of the industrialized era and shows the designer's precise consideration of the material utilization rate. The tea table as a whole is combined by two panels and then used together with the table top, and the panels supporting the feet are divided into two pieces of Yin and Yang, which are engaged with each other to maximize the utilization rate of the panels.

The panel tea table is made of MDF board through powder spraying process, which has the advantages of high strength, high stability, etc. The use of hidden hardware ensures the appearance design of Plank panel tea table while improving the stability. The tea table can be kept stable without deformation.

There are two series of panel tea tables, totaling four models, which well meet the needs of tea tables of different sizes. The square model is more stable and suitable for business, while the round model is more lively and suitable for leisure. The two series have both practicability and beauty. It can be placed not only in leisure areas, tea areas and other office leisure areas, but also in business negotiation areas and other office places.



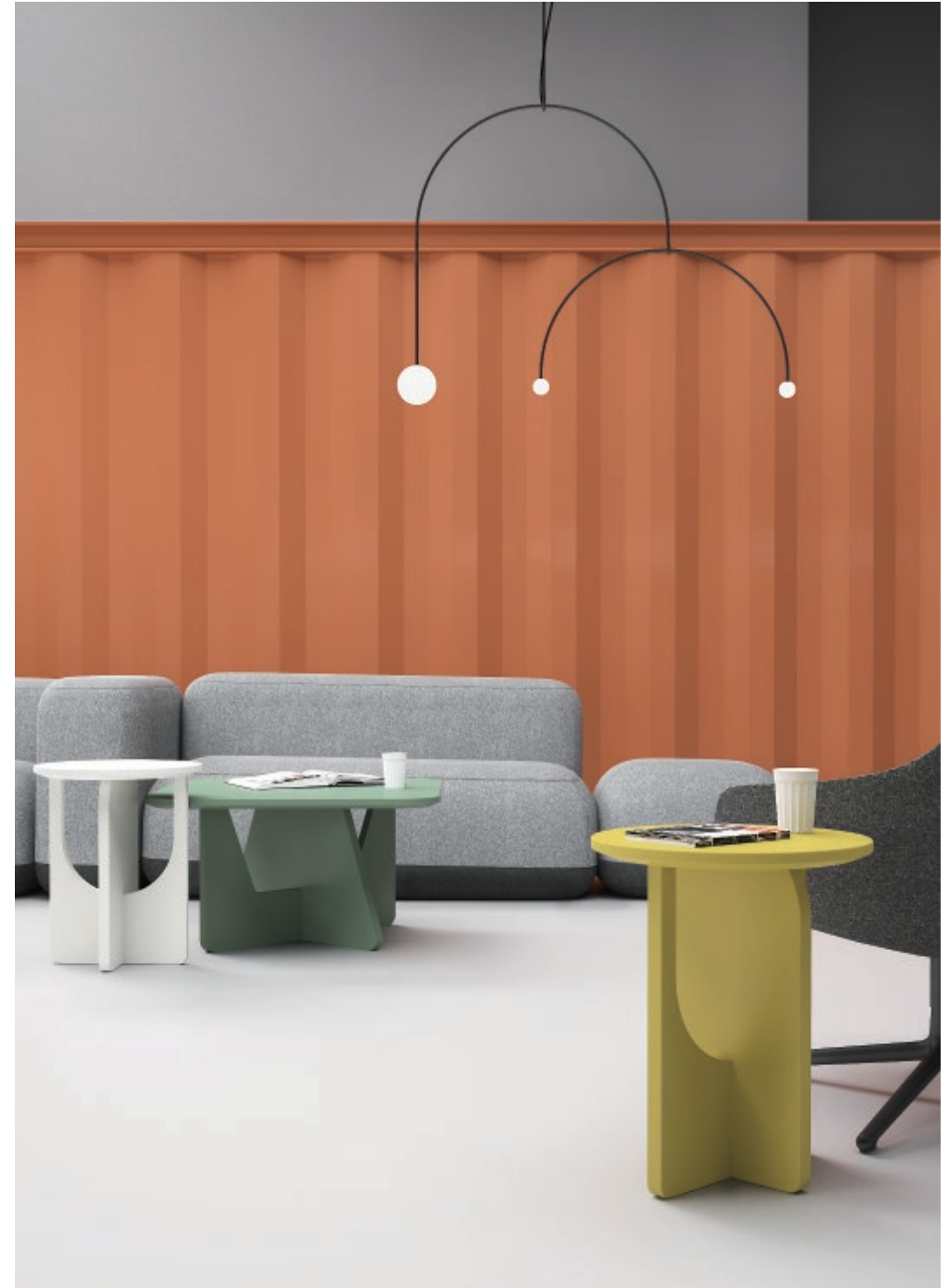

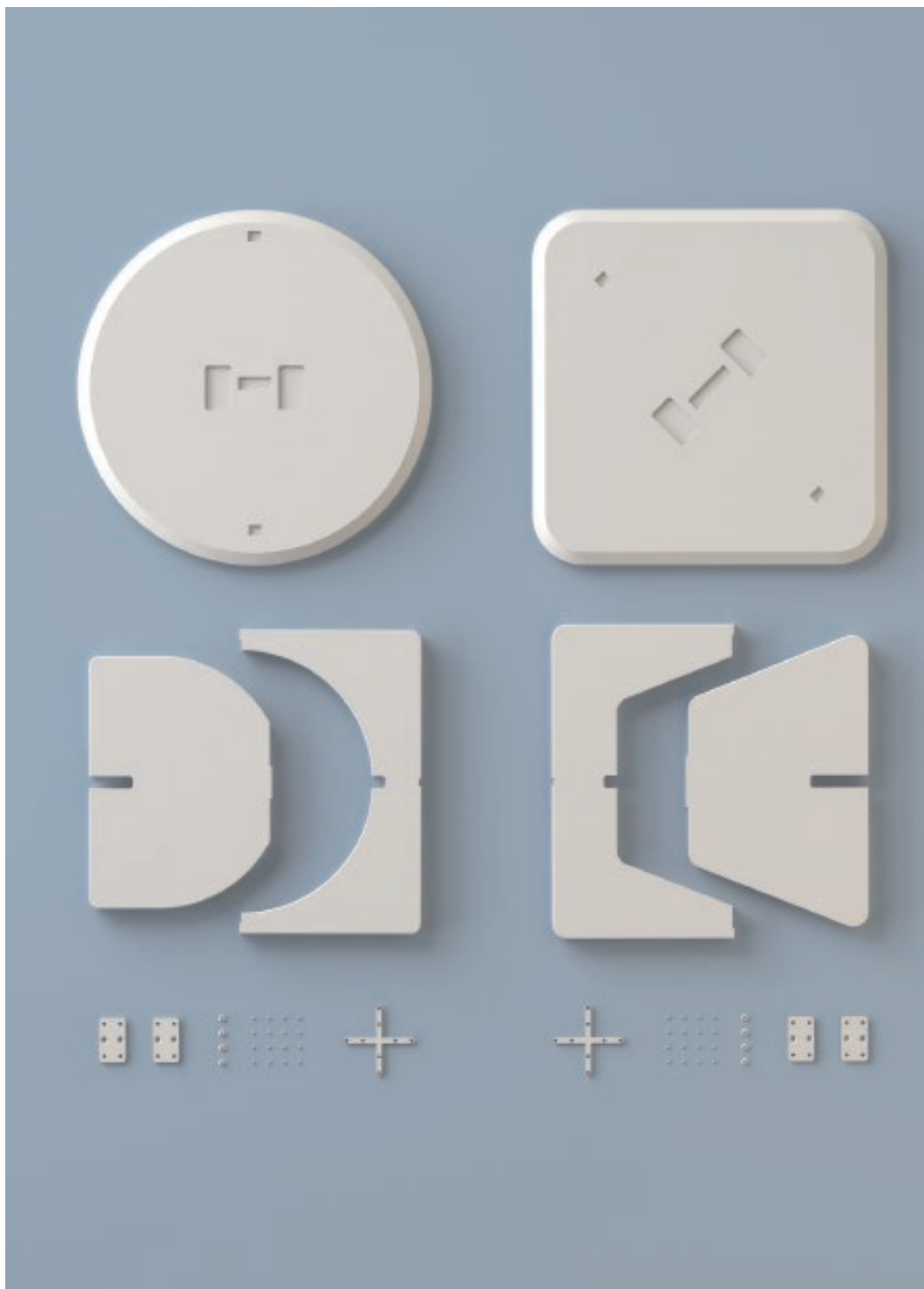

AR-PLA-TB-01
Φ700 H380



AR-PLA-TB-02
Φ380 H465



AR-PLA-TB-03
W700 D700 H380



AR-PLA-TB-04
W400 D400 H470

PRODUCT SIZE

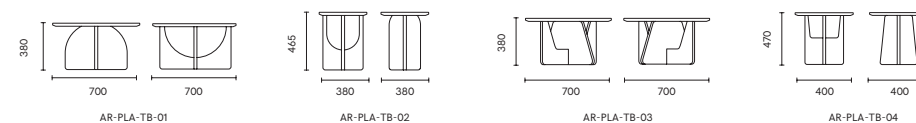

COLOR OPTIONS





ORIGIN

The design returns to the most primitive modeling elements. It seeks the perfect combination of form and function in the arrangement and combination of points, lines and surfaces. The clean and pure modeling language ensures the simplicity of this tea table without losing its details.

The origin tea table has two styles of round table top and square table top, which can be flexibly matched in different space environments to meet different use requirements.

The desktop of the origin tea table is made of medium density fiberboard, and the surface is painted with various colors. The support is welded from seamless steel tubes, and the table top and the support are made into a simple and clean whole through ingenious structural methods. The simple shape and light weight of the origin tea table can be convenient for users to carry, making it suitable for places such as leisure areas and tea areas.





AR-ORI-TB-01
W385 D320 H580



AR-ORI-TB-02
W380 D380 H580

PRODUCT SIZE

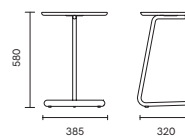

AR-ORI-TB-01

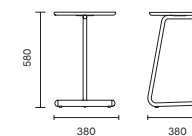

AR-ORI-TB-02

COLOR OPTIONS



WHALE

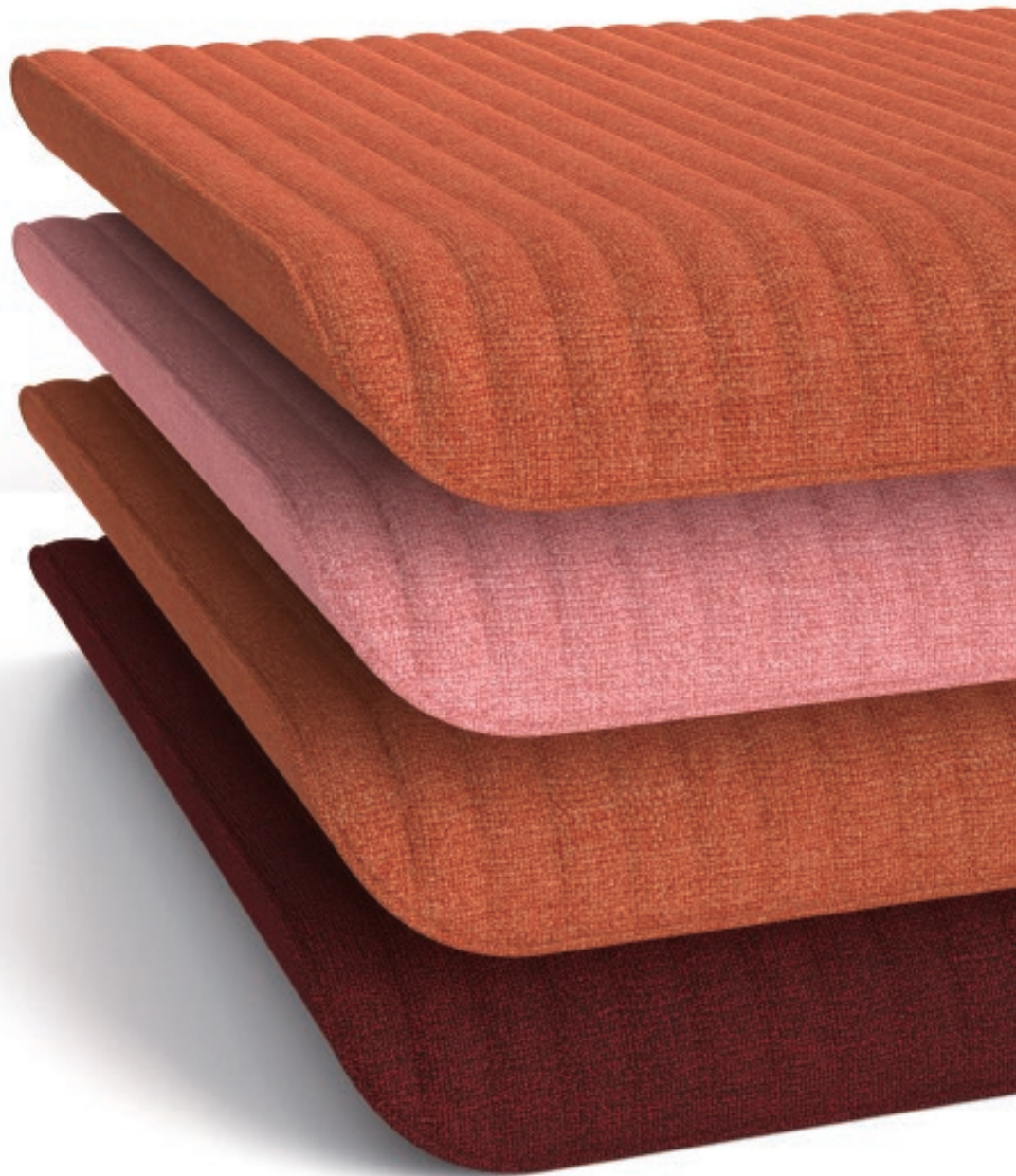

The shape design of the whale cushion was inspired by the marine creature whale. The upturned ends of the cushion perfectly show the smooth body curve of the whale. The design of the sitting surface adopts the belly stripes of whales and is interpreted by modern techniques. A cushion with unique appearance and strong design feeling has been created.

For centuries, whales have often been used as raw materials for table delicacies or industrial products, which has led to a sharp decline in the number of whales. Whales have become an endangered species. Through the power of design, designers hope to appeal to more people to pay attention to the current situation of whales and arouse people's sympathy to protect nature's creatures.

In the choice of fabric, the whale cushion is embossed with fabric, and the feeling of blocking and soft touch brought by stroking brings different experiences to users. At the same time, the choice of a variety of fabrics adds life to the office space and better reflects the whale's design language.

Whale cushions are of the general size on the market. It can satisfy the use of multiple scenes and spaces, embellish public spaces such as training, lecture halls, leisure and entertainment, and add interest to office space.





AR-WHA-CU
W450 D450 H80

PRODUCT SIZE

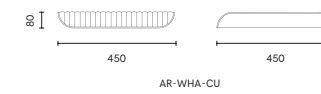

MATERIAL / HY

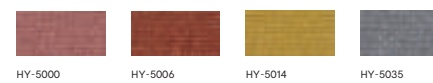

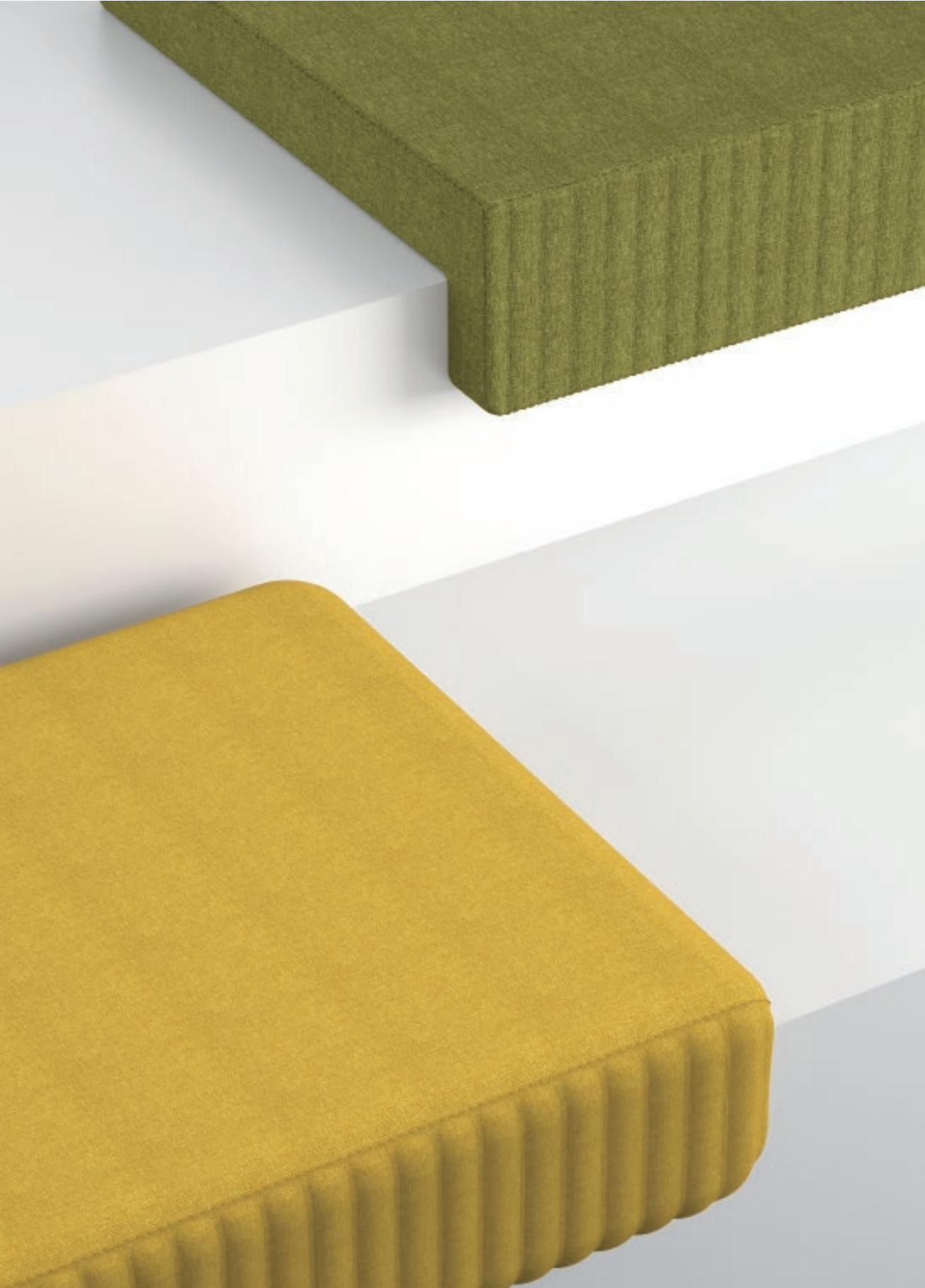

TAIL

The shape of the fishtail cushion was inspired by the fish tail.

The overall shape of the cushion is L-shaped. It looks like fish tail swinging in the water. The L-shaped design is suitable for stepped conference space to avoid accidental bumping of users and plays a protective role. The bottom of the cushion is equipped with an anti-skid cushion layer, which optimizes the experience of staff in the office process and reflects the humanistic care of the brand.

In the choice of fabric color, the cushion also has blue, yellow and gray. Cold and medium colors make people more focused in office space, while the use of bright colors can make the space full of vitality.

In terms of fabric selection, the cushion is also equipped with a variety of colors such as blue, yellow, green and gray. Cool color and medium color make the office space more focused, and the use of bright color can inject vitality into the space.

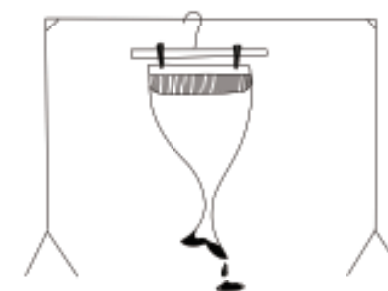



AR-TAI-CU-01
W460 D460 H135



AR-TAI-CU-02
W460 D460 H135

PRODUCT SIZE

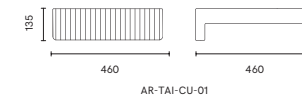

AR-TAI-CU-01

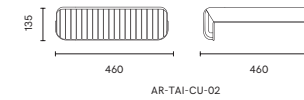

AR-TAI-CU-02

MATERIAL / HY

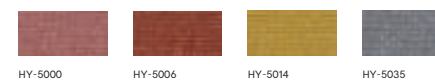

HY-5000

HY-5006

HY-5014

HY-5035

MACAROON



In history, macaroon was a noble food and a symbol of luxury. With the development of history, it has gradually entered the life of the public and won people's love with its colorful color, fresh and delicate taste and small and exquisite shape. By borrowing elements from macaroon, the designer created this delicate and lightweight cushion.

The design of the cushion zipper makes the cushion unique. The cushion can be removed and cleaned or the cushion cover can be purchased again, thus prolonging the service life of the product. In addition, the zipper design makes it easy to take off and portable, enhancing the interaction between people and product. The double-piping design of the cushion makes the cushion more delicate and improves the quality of the product.

The overall shape of the cushion is round, which is the basic cushion needed in the market. It is different from the same type of products in the market in that it combines the two-color design of macaroon elements to enrich product details. The light-weight shape allows macaroon to be scattered at will or placed in groups of three or two to meet different needs and become an ornament for public spaces such as leisure and training.





AR- MAC-CU
W460 D460 H80

PRODUCT SIZE

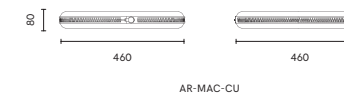

MATERIAL / HY

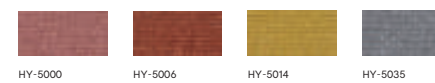



FAN

Fan divider series is inspired from the culture of China ancient fan, which is an innovative concept for space dividers in public area. The expression of concretization can directly share a lounge feeling with people. Fan divider series provides sound insulation for the needs of resting and meeting, to create a privacy and beautiful area for people.

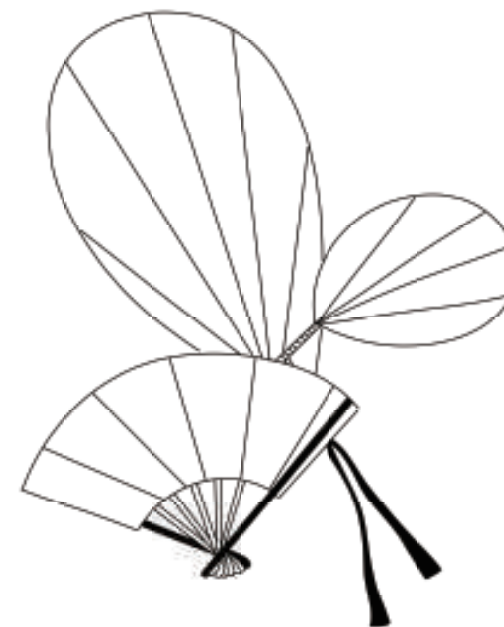





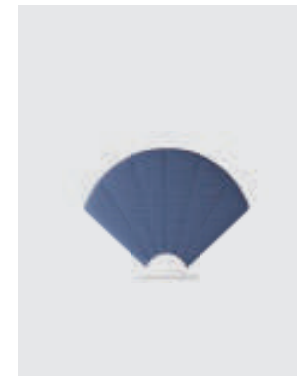

AR-FAN-SC-01
W1600 D310 H1240

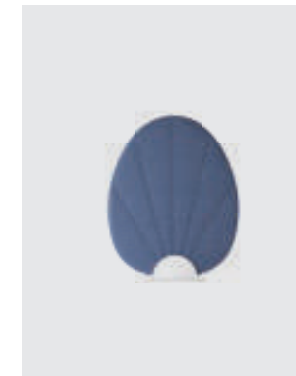

AR-FAN-SC-02
W1200 D310 H1520

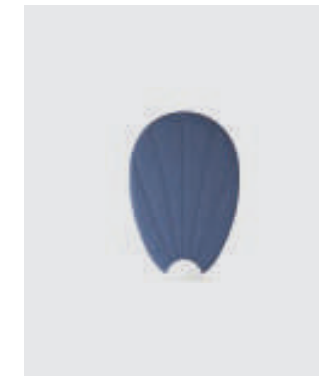

AR-FAN-SC-03
W1200 D310 H1840

PRODUCT SIZE

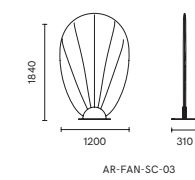
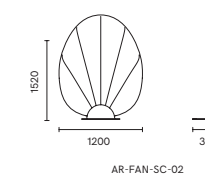
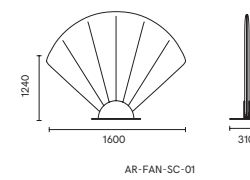

MATERIAL / YM



MATERIAL / LIDO



CONTENTS

CHAIR & LOUNGE

HUG	04
SYS	10
ELEPHANT	16

SOFA

FLOWER	26
COOKIE	34
SNOWCAP	42
POD	50
HOBBYHORSE	60
MULTI	68
SANTO	74
ONE-CORNER	80
	86

ACCESSORIES

ELEPHANT	16
ROMA	68

Product Overview

Hug - 2022



SYS - 2022



Elephant - 2022



Flower - 2022



Cookie - 2022



Snowcap - 2022



Pod - 2022



Hobbyhorse - 2022



Roma - 2022



Multi - 2022



Santo - 2022



One-Corner - 2022





HUG

The Hug Chair extracts the behavioral element of embracing, which conveys emotions, as the design basis. It extracts the curve of raising your arms to obtain a hug, and combines it with warm solid wood materials to create its unique emotions and rhythms. When users use furniture, it seems as if there is a mother hugging tightly behind them, giving the furniture a new meaning of life.

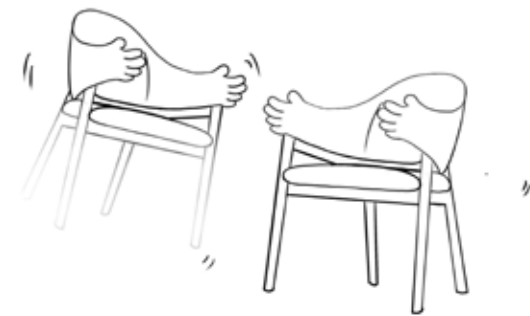



The warm and colorful shape of the hug chair can be applied to various spaces





AR-HUG-CH-01
W625 D575 H760

PRODUCT SIZE

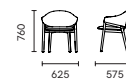

AR-HUG-CH-01

MATERIAL / MINA



MIN-02 MIN-18 MIN-20 MIN-21 MIN-23

MATERIAL / VICO



VIC-09 VIC-33 VIC-39 VIC-21 VIC-41



SYS

In the SYS chair series, designers combine the language of shell texture with fabric technology to play on the chair surface. An elegant line game. The vertical ribs on the surface of the fabric adopt the embossing process, which brings about resistance when touching. The sudden sensation and soft touch bring users a different use experience. Multiple color choices can better meet the requirements. Matching needs of different customers and different spaces. The overall contour of the chair is warm and elegant, and each curve is based on the curve of the human body is carefully adjusted to provide users with a comfortable seating experience. The SYS steel foot leisure chair is an extension of the SYS chair series, with significant changes made to the tripod. The design of the tripod half surrounding the soft backrest makes the product more integrated and more secure.





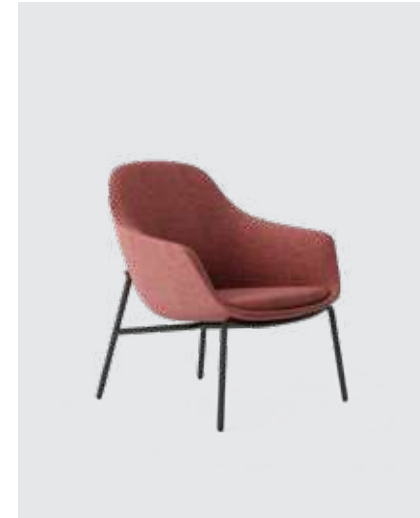

AR-SYS-AR-01
W745 D740 H815

PRODUCT SIZE

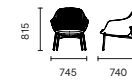

AR-SYS-AR-01

MATERIAL / SUNDAY



SUN-10 SUN-83 SUN-45 SUN-69 SUN-21



ELEPHANT

The Elephant Series is inspired by elephants with stable limbs. Designers have extracted the characteristics of elephants such as their huge ears and thick backs, and applied them to the software of furniture. From the aspect of use, various products with huge application space such as piers, benches, and leisure chairs have been derived.

The seat surface is folded down in one piece, and the slightly arched seat surface echoes the backrest, making the design of the Elephant series products simple and smooth, with distinct characteristics.

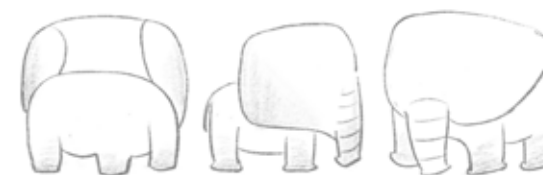







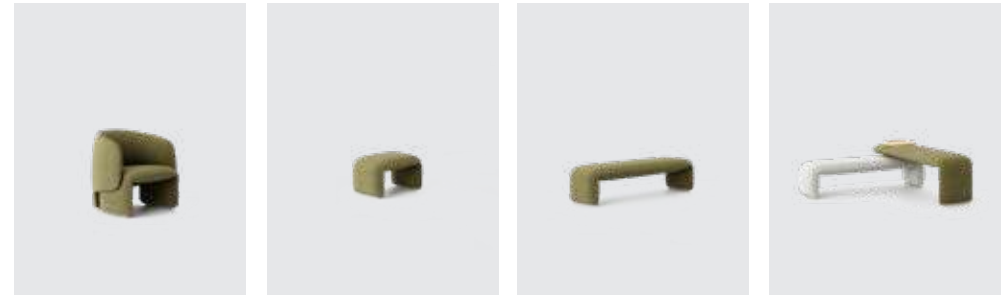

AR-ELE-AR-01
W750 D760 H760

AR-ELE-BE-01
W700 D510 H410

AR-ELE-BE-02
W1600 D510 H410

AR-ELE-BE-03
W1600 D1600 H550

PRODUCT SIZE

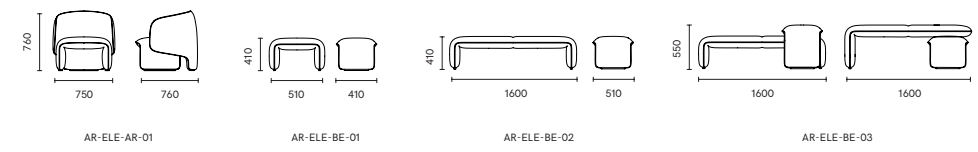

MATERIAL / VICO



MATERIAL / LEA





FLOWER

The Flower sofa comes from the blooming flowers. The designer extracts the posture of the petals when they are in full bloom from the appearance image of the flowers, and adds piping embellishments to the outward opening armrest, making the petal sofa more vivid and spiritual. The multi module combination of petal sofas greatly meets various usage spaces, with more matching options.









AR-FLO-SO-01 W1495 D905 H730 AR-FLO-SO-02 W1200 D905 H730 AR-FLO-SO-03 W1200 D905 H730 AR-FLO-SO-04 W1855 D1200 H730 AR-FLO-SO-05 W1855 D1200 H730



AR-FLO-SO-06 W1980 D1255 H730 AR-FLO-SO-07 W1980 D1255 H730 AR-FLO-SO-08 W840 D905 H730 AR-FLO-SO-09 W1580 D855 H730

PRODUCT SIZE

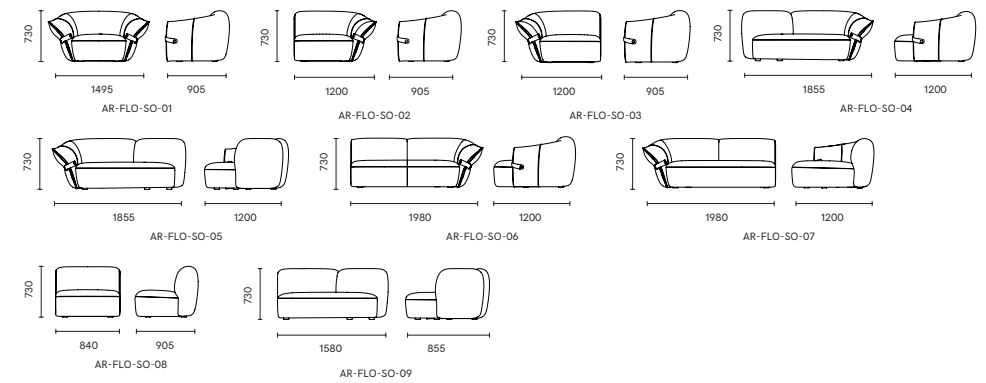

MATERIAL / LEA

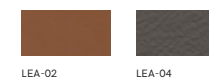



COOKIE

The ingenuity of the cookie sofa originates from the concentric circle shape in nature, and it has a flexible state of "individual parts are complete, and unity is unparalleled in the world". Its shape has a soft, rounded, and harmonious feeling. It is like a big family, where SKUs can be independent or modular, aesthetically pleasing and user-friendly, not only enhancing the fun of the space, but also providing users with more choices.

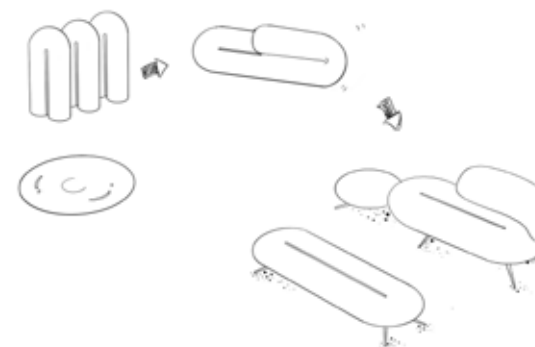





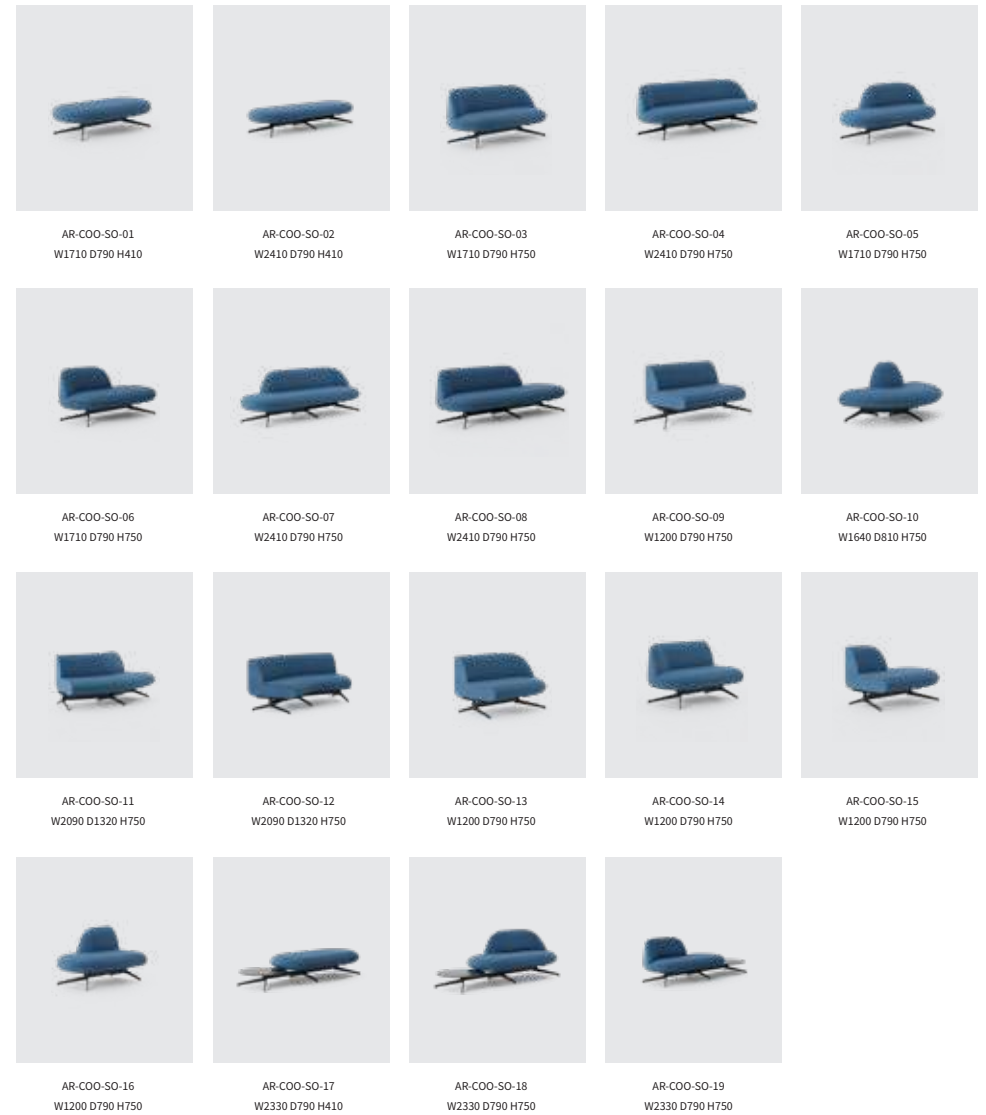



SNOWCAP

The snowscape sofa comes from the architecture of snow in winter. The designer refined the soft modeling language of snow, overlaying the hard main body with soft and fluffy soft bags to form a sharp contrast, and derived a tripod style from the use aspect. The whole product is made in the form of a full soft bag, with a strong sense of quality.







The rounded corners at the front of the armrests of the snowscape sofa follow the traditional Archini style, with the armrests soft as snow and the unique shape of a double layer soft bag.





AR-SNO-SO-01
W1090 D850 H700



AR-SNO-SO-02
W2000 D850 H700



AR-SNO-SO-03
W2300 D850 H700



AR-SNO-SO-04
W1090 D850 H700

PRODUCT SIZE

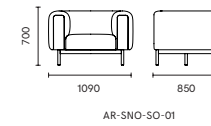

AR-SNO-SO-01

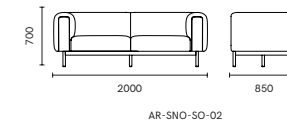

AR-SNO-SO-02

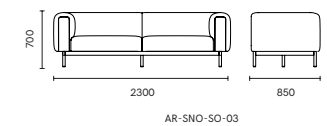

AR-SNO-SO-03

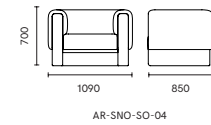

AR-SNO-SO-04

MATERIAL / FLOWER

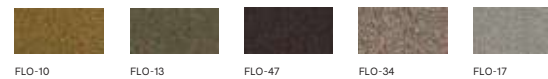

FLO-10

FLO-13

FLO-47

FLO-34

FLO-17



POD

The inspiration for the pod sofa comes from the pod. The designer applies the full and undulating lines of the pod to the back of the sofa, with a rounded and thick back surrounding the entire cushion and a forward extension forming an armrest. Multiple SKUs can be placed in multiple combinations to meet space requirements.

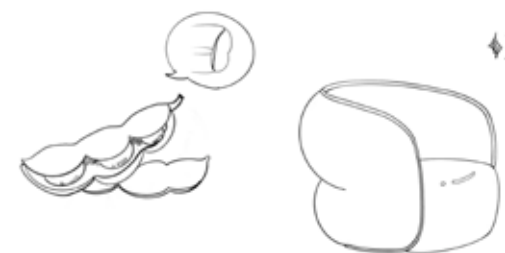









AR-POD-SO-01 W1000 D860 H730 AR-POD-SO-02 W2430 D860 H730 AR-POD-SO-03 W2430 D1060 H730 AR-POD-SO-04 W1330 D1330 H730 AR-POD-SO-05 W1500 D860 H730



AR-POD-SO-06 W1500 D860 H730 AR-POD-SO-07 W1400 D1060 H730 AR-POD-SO-08 W1400 D1060 H730 AR-POD-SO-09 W1500 D1060 H730 AR-POD-SO-10 W1500 D1060 H730

PRODUCT SIZE

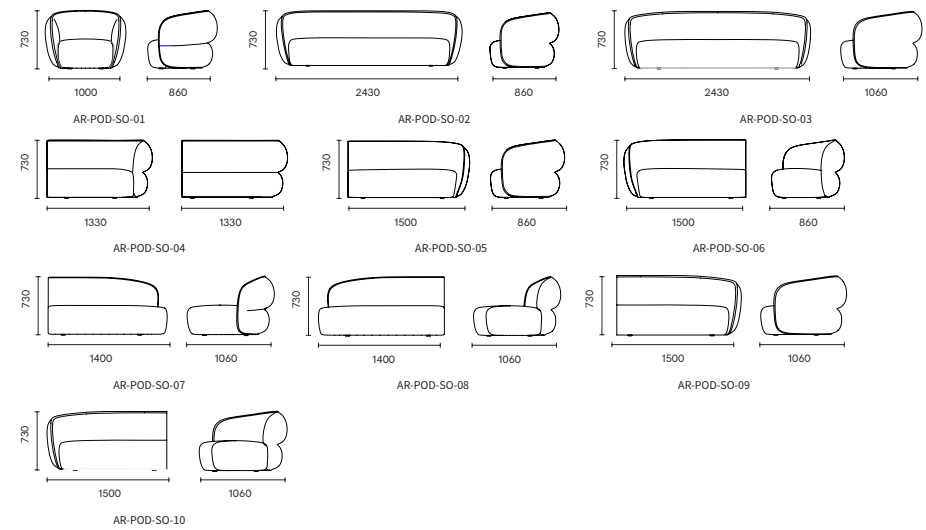

MATERIAL / SUNDAY





HOBBYHORSE

The Hobbyhorse Lazy Sofa comes from the rocking Trojan Horse. The designer integrates the characteristics of the rocking Trojan Horse that can swing back and forth into the lazy sofa. When using it, a slight swing can not only alleviate the fatigue of static muscle exertion, but also evoke childhood memories and quickly relax from the tight state of office work. The surface embossed cloth cover can be removed for easy cleaning, and can also be colored according to customer preferences.

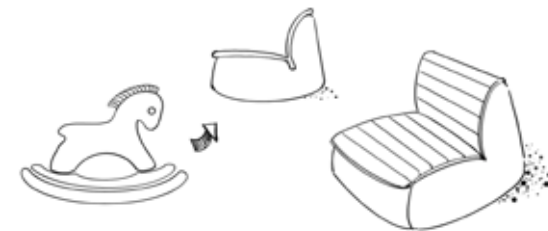







AR-HOB-SO-01
W755 D925 H685

PRODUCT SIZE

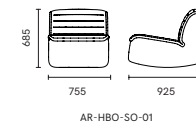

MATERIAL / SUNDAY



SUN-10 SUN-83 SUN-45 SUN-69 SUN-21

MATERIAL / FLOWER



FLO-10 FLO-13 FLO-47 FLO-34 FLO-17



ROMA

The inspiration for the ROMA series comes from Roman architectural elements - arches and Roman columns. The designer integrates these two elements into modern office behavior, creating a furniture that combines privacy and practical functions for users, while creating a small building that stands upright in the office and leisure area.







AR-ROM-ST-01
W1075 D800 H2000



AR-ROM-SC-01
W820 D655 H1100



AR-ROM-SC-02
W1015 D460 H1715

PRODUCT SIZE

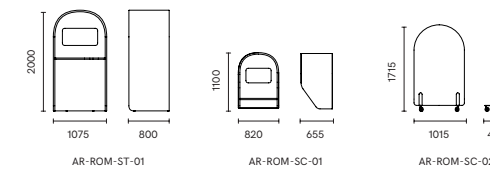

MATERIAL / SUNDAY





MULTI

This is an extension of the thousand-storey sofa, inspired by the orderly and rhythmic lines and surfaces of skyscrapers. The designer will extract this design language for interpretation, demonstrating the dynamic and vibrant modern temperament of the sofa.







AR-MUL-HI-01
W1000 D850 H1200

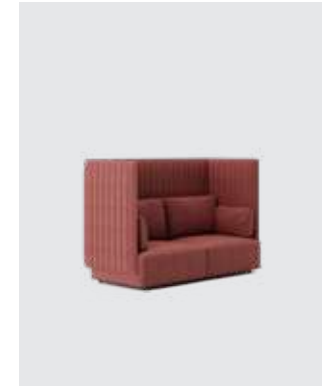

AR-MUL-HI-02
W1835 D850 H1200

PRODUCT SIZE

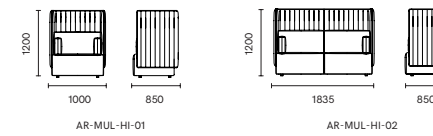

MATERIAL /MINA





SANTO

Santo Serialization is an extension of the Santo sofa system, which differs from the former in that it extends two types of SKUs: inner arc and outer arc. Its inspiration comes from winding mountain roads and circular roads, which are combined to form beautiful curves. It not only increases the applicability and selectivity of the product, but also can meet the use requirements of arc, curve, and circle in user space.







AR-SAN-SO-28
W1300 D660 H760



AR-SAN-SO-29
W1300 D660 H760

PRODUCT SIZE

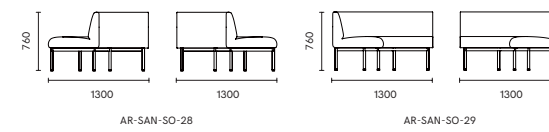

MATERIAL / SUNDAY





ONE-CORNER

The inspiration for the corner sofa comes from a corner of the street. The designer extracts the modeling characteristics of the eaves of the corner buildings and applies them to the software of furniture to express a peaceful and comfortable artistic conception, allowing the dull office space to emerge with the relaxed and comfortable corner alleys, making people relaxed and happy.

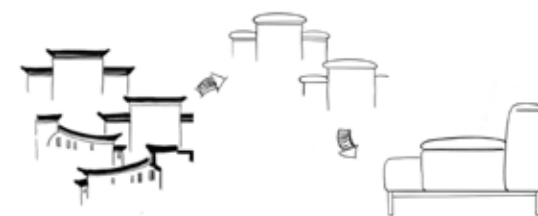





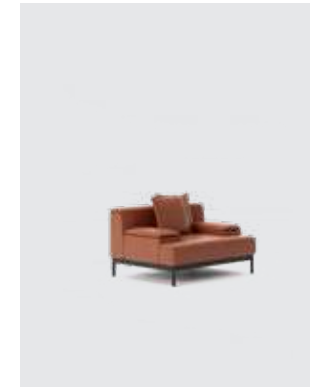

AR-ONE-SO-01
W1180 D940 H710

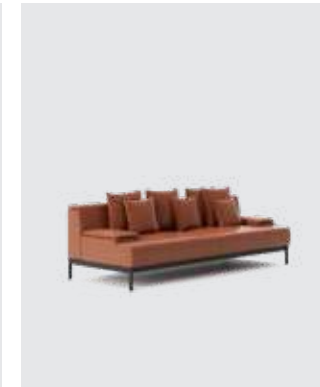

AR-ONE-SO-03
W2210 D940 H710

PRODUCT SIZE

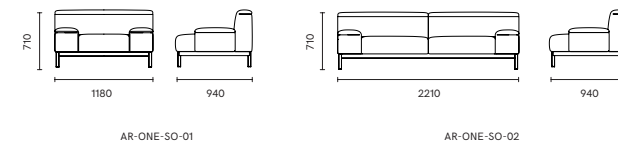

MATERIAL / VICO



MATERIAL / LEA



CONTENTS

CHAIR & LOUNGE

STALACTITE	05
JELLFISH	15
KOJI	25
RAIN FLOWER	33
MUSHROOM	41
PINE CONE	49
TOAST	57

OFFICE CHAIR

SWAN	69
SUNRISE	79
ALMOND	89

SOFA

LOTUS	101
TOFU	111

Pouf

ZOO	123
-----	-----

TABLE

NUMERATOR	135
-----------	-----

Product Overview

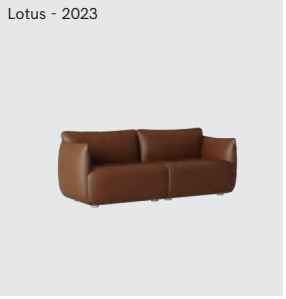
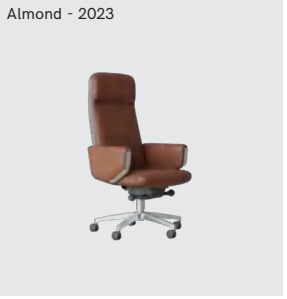



Nature's stalactites inspired the designer to create the stalactite chair. The chair cleverly combines the shape of stalactites, with the soft body showing the beauty of softness and strength. The U-shaped metal base draws on its hanging fulcrum, which not only improves comfort but also gives the chair a sculptural artistic feel. It makes you feel like you are in the embrace of nature.





INTRODUCING STALACTITE

DESIGN BY COLLECTIVO



In the soft part of the chair, the designer cleverly simulated the shape of stalactites, making the chair present a beauty that is both soft and full of power. Sitting up, it seems like one can feel the gentle embrace of nature.







PRODUCT SIZE

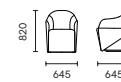

AR-STA-CH-01

MATERIAL / FLOWER



FLO-07

FLO-10

FLO-13

FLO-17

FLO-20

MATERIAL / VICO



VIC-09

VIC-33

VIC-39

VIC-21

VIC-41



The Jellyfish Chair is inspired by the refinement of its shape and cleverly uses the contrast between the upholstery and the base to show a rich sense of layering. The folding design of the soft bag simulates the rhythm of the jellyfish and provides a comfortable sitting experience. The Archini brand is also inspired by the regenerative capacity of the jellyfish, striving for environmental protection and durability, demonstrating its thinking and practice of sustainable development.

JELLYFISH





INTRODUCING JELLYFISH

DESIGN
BY COLLECTIVO



Cleverly, the designer simulated the movement of jellyfish in the water by folding the soft bag. This design not only makes the chair look more vivid, but also brings a comfortable sitting experience to the user. When people sit on it, they seem to feel the light and graceful rhythm of jellyfish, bringing a touch of relaxation and comfort to their busy office life.







PRODUCT SIZE

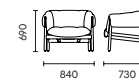

AR-3EL-AR-01

MATERIAL / MINA



MATERIAL / VICO





The design of KOJI Lounge Chair is inspired by candy canes. It integrates unique shapes and circle elements into the software design, bringing festive surprises. In-depth consideration is given to human-machine comfort, and the changes in the size of the soft package circle enrich the sense of layering and enhance the comfort experience. Deliver the warmth and happiness of candy and bring relaxation and joy to busy life.





INTRODUCING KOJI

DESIGN BY COLLECTIVO



The designer cleverly captured the unique curved and tangled shape and popular circular elements of cane candy, extracted and simplified its essence, and then cleverly integrated it into the soft design of furniture.





PRODUCT SIZE

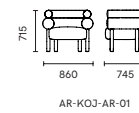

MATERIAL / RUBY



MATERIAL / WALES





The design of the Rain Flower Leisure Chair is inspired by the Nanjing Rain Flower Stone, refining its simple and round shape language and integrating it into the software design to show modern and traditional charm. The lines are smooth and rounded, like Yuhua stones that have been baptized by time, exuding a tranquil and elegant atmosphere. The chair carries the meaning of good luck and auspiciousness, bringing good wishes and strength to the home and office.

RAIN FLOWER





INTRODUCING RAIN FLOWER

DESIGN
BY COLLECTIVO



From the use of derivatives of the seat pier, bench, lounge chair and other applications of great space products. Its modules through the flexible combination of matching, the formation of leisure space, discussion space, aisle space and corner space, etc.





PRODUCT SIZE

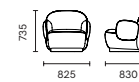

AR-RAI-AR-01

MATERIAL / RUBY



MATERIAL / WALES





The design inspiration of Mushroom Chair comes from cleverly capturing its morphological characteristics and integrating them into the chair design. The backrest and armrests simulate small mushroom umbrellas to provide comfortable support; the pleated design restores the structural characteristics of mushroom veins. The soft inside and hard outside design ensures comfort and stability, and the two-color treatment enhances the visual impact. We hope that users can feel the vitality of nature and find a moment of peace and relaxation while using it.

MUSHROOM





INTRODUCING MUSHROOM

DESIGN
BY COLLECTIVO



The mushroom leisure chair adopts a soft inside and hard outside design, ensuring both user comfort and chair stability. The dual color treatment adds a strong visual impact to this chair, making it stand out among many furniture items.





PRODUCT SIZE

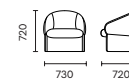

AR-MUS-AR-01

MATERIAL / RUBY



MATERIAL / WALES





The Pine Cone Lounge Chair incorporates its form and symbolic meaning into the design, presenting the beauty of natural harmony. The characteristics of the pine cone shape are extracted and applied to the software part, and the color separation treatment enhances the visual impact. The soft inside and hard outside improve comfort and meet the cultural pursuit of "lying flat". Pinecones secrete dopamine, which brings physical and mental pleasure to users.

PINE CONE





INTRODUCING PINE CONE

DESIGN BY COLLECTIVO



The designer applied the plump and round shape characteristics of pine cones to the soft part of the leisure chair, making the entire chair look both soft and comfortable. At the same time, combined with the distinct layering of pine cones, the designer has carried out color separation treatment on the soft bag, further enhancing the visual impact of the chair.





PRODUCT SIZE



AR-PIN-AR-01

MATERIAL / RUBY



MATERIAL / WALES





The Toast Lounge Chair integrates the softness and sweetness of Western bread into the office scene. The appearance is made of high-quality leather, which is comfortable to the touch and durable. The shape draws on the warmth and comfort of toast bread, with smooth and graceful lines. It pays attention to ergonomic design and is equipped with a footrest to provide users with comfortable support and rest space, allowing users to enjoy tranquility and relaxation after busy work.

TOAST



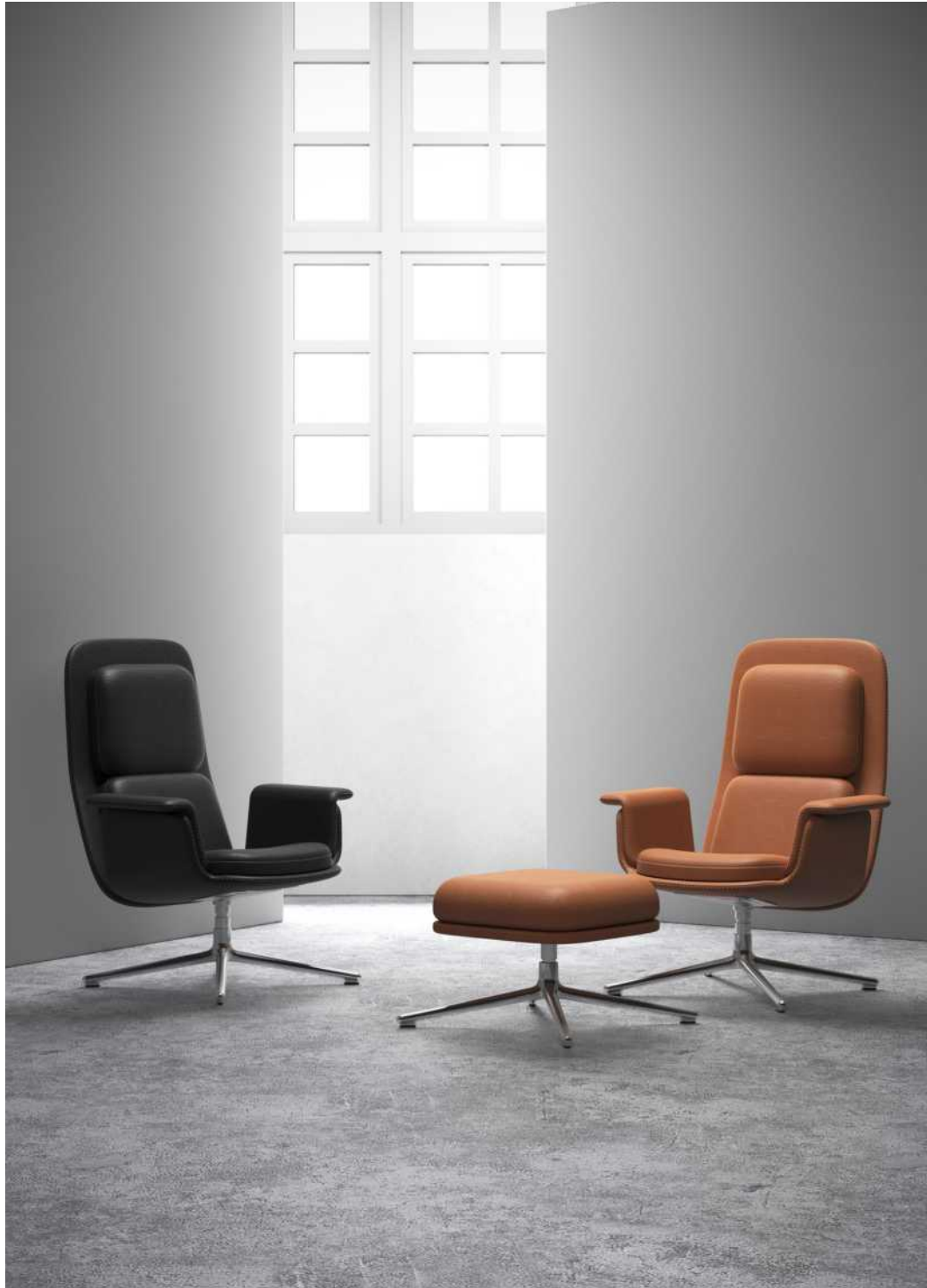

INTRODUCING TOAST

DESIGN
BY COLLECTIVO



In addition to its advantages in appearance and seating experience, the toast leisure chair also emphasizes ergonomic design, ensuring that users can still maintain comfort and health in long-term sitting positions. The equipped footstool provides users with additional support and rest space, allowing them to relax and enjoy a moment of tranquility while busy with work.







PRODUCT SIZE

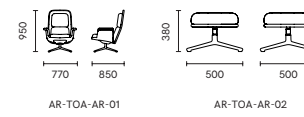

MATERIAL / LEA





The swan leather chair cleverly combines modernity and design beauty. Its design is inspired by the elegance of the swan, showing smooth and noble lines. The chair not only looks beautiful, but is also practical and comfortable. The designer hopes that this chair will stand out among many leather chairs, show the infinite possibilities of modern home design, and bring beauty and surprise to users.

SWAN



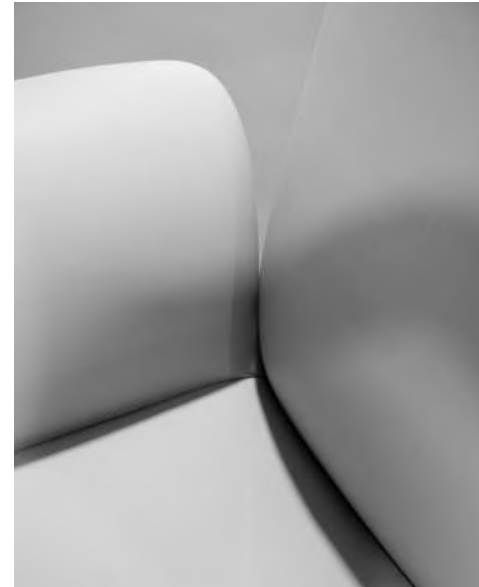

INTRODUCING SWAN

DESIGN
BY COLLECTIVO



The design lines of this leather chair are smooth and elegant, like a swan swimming in the water spreading its wings, quiet and noble. The overall shape of the chair is full of power, and each angle exudes unique design charm.







PRODUCT SIZE

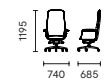

AR-SWA-OC-03

MATERIAL / LEA





In the post-epidemic era, the Sunrise Leather Chair launched by Archini has become a creative choice to rejuvenate the office. The chair cleverly integrates the natural beauty of the sunrise, which not only looks beautiful, but also enhances the office experience. Carefully designed for comfort and durability, allowing users to feel relaxed. The Sunrise Leather Chair symbolizes new beginnings and hope, inspiring people to actively face challenges and injecting new vitality into the office environment.

SUNRISE





INTRODUCING SUNRISE

DESIGN BY COLLECTIVO



The symbolism of the sunrise leather chair also deeply moves people. It represents a new beginning and endless hope, as if telling every user: no matter how busy and difficult our work is, we should maintain a positive attitude and embrace every new challenge and opportunity.



The design of the Sunrise leather chair is not only for aesthetics, but also to enhance the user's office experience. The comfort, support, and durability of the chair have been carefully designed and rigorously tested to ensure that users can feel unparalleled comfort and relaxation during use.







PRODUCT SIZE



AR-SUN-OC-02



AR-SUN-OC-03

MATERIAL / LEA





The Snowcap Sofa is an expression of an architectural scene in the snow. Its design reflects the designer's extreme pursuit of detail. By refining the fluffy modeling elements of snow. It forms a perfect combination of soft and fluffy upholstery and hard body. Layered sense and fluffy sense.





INTRODUCING ALMOND

DESIGN
BY COLLECTIVO



In office settings, such a vibrant leather chair can bring joy and relaxation to people, making work easier and more efficient. It perfectly combines natural elements with humanistic sentiments, bringing people a unique comfort and laziness, allowing them to find peace and beauty in their busy work and life.



ALMOND

ALMOND



ALMOND

The designer combined the distinct layering of almonds and applied them to the software and touch board. This design not only increases the layering and three-dimensional feel of the chair, but also makes the sitting experience more comfortable.





PRODUCT SIZE

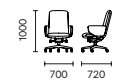

AR-ALM-OC-02

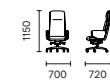

AR-ALM-OC-03

MATERIAL / LEA



LEA-01

LEA-02

LEA-03

LEA-04

LEA-05

SOFA

2023
Design by Collectivo

SOFA

SOFA

Building In The Building



The designer draws on the beauty and connotation of the lotus and cleverly integrates it into modern office design. The design of the sofa is inspired by lotus petals, with the armrests and backrests wrapping the sitting surface like petals, showing flexibility and liveliness. The lines are smooth and elegant, creating a tranquil and profound atmosphere. This design not only inherits culture, but also innovates modern lifestyle, improves work efficiency and brings peace of mind.

LOTUS



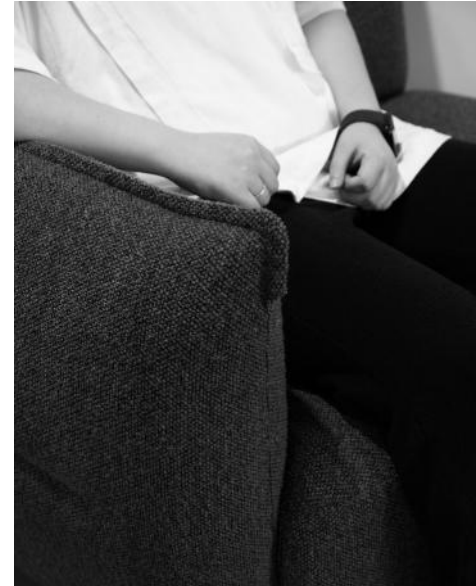

INTRODUCING LOTUS

DESIGN BY COLLECTIVO



The overall design of the sofa not only highlights the agility and liveliness of the lotus, but also showcases its profound cultural connotations in the details. The lines of the seat and armrest are smooth and elegant, like the gentle swaying posture of a lotus in the water, giving people a peaceful and profound feeling



Through this design language, the connotation of lotus has been successfully integrated into the office scene, making the entire space full of a peaceful and harmonious atmosphere. Working in such an environment not only improves work efficiency, but also allows people to feel a sense of spiritual tranquility and relaxation.





PRODUCT SIZE

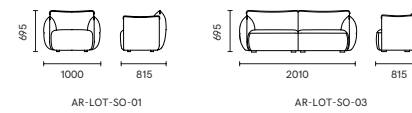

MATERIAL / MINA



MATERIAL / VICO





Tofu sofa combines traditional tofu elements with modern home design, creating a stable image with tofu geometric shape, which is in line with the business atmosphere. The detail processing simulates the dynamic language of "scallions mixed with tofu", reflecting the blend of flexibility and rigidity. The metal decorative strips on the side add a sense of sophistication and highlight the designer's ultimate pursuit of details, creating a business sofa with both cultural heritage and modern aesthetics.

TOFU





INTRODUCING TOFU

DESIGN BY COLLECTIVE

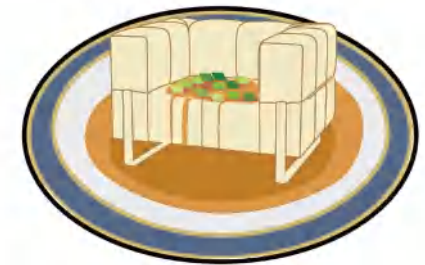

The designer added intricate details to the combination of the sofa software and the tripod, vividly simulating the abstract dynamic language of the traditional dish of "stir fry tofu with scallions".



The metal decorative strips on the sides add more details and texture to the product, making the overall sofa more exquisite and high-end. This design not only enhances the visual effect of the sofa, but also reflects the designer's ultimate pursuit of product details.







PRODUCT SIZE

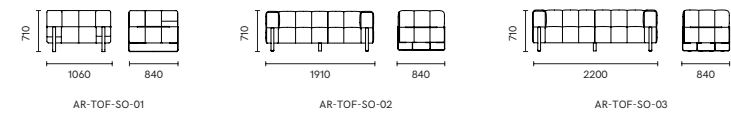

MATERIAL / MINA



MATERIAL / VICO



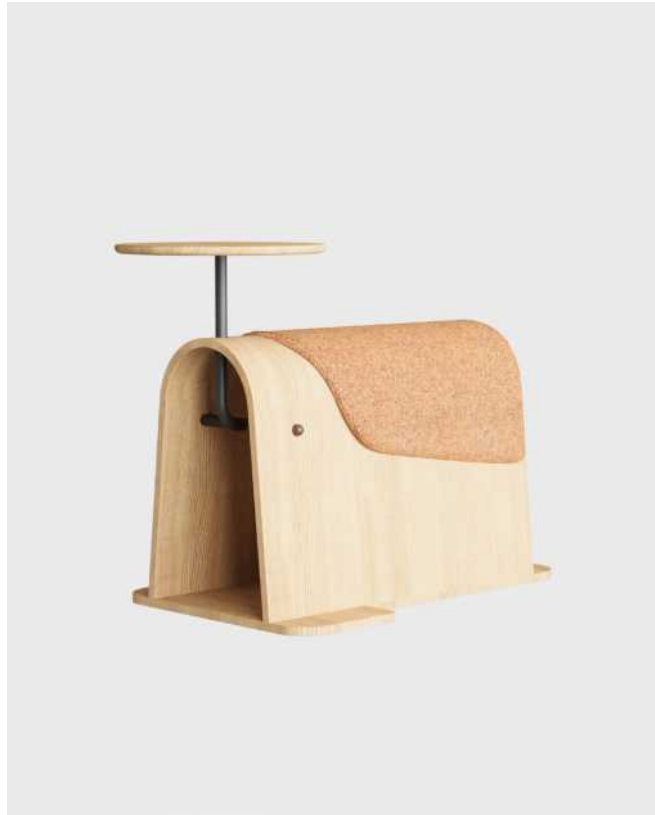

Archini's office furniture designs are innovative and respectful of traditional culture. The Zoo series draws on the elements of "shadow play" and incorporates vivid silhouettes, giving the products artistic beauty and vitality. It is highly flexible, allowing users to freely choose their sitting position, and is equipped with a small table to improve office efficiency. The Zoo series shows the charm of traditional culture with interesting design and improves the quality of the office environment.

ZOO





INTRODUCING ZOO

DESIGN BY COLLECTIVO



The flexibility of the Zoo series is also a major highlight. Users can choose to sit sideways or upright according to their needs and preferences, greatly improving the comfort and freedom of use. At the same time, the product is also equipped with an optional small desk, which is convenient for users to use during work, making the office environment more efficient and convenient.







PRODUCT SIZE

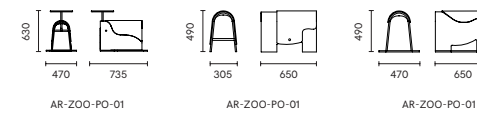

MATERIAL / SUNDAY



MATERIAL / VICO





The design of the molecular coffee table series is inspired by the molecular structure of the microscopic world, combining the wonders of nature with practicality to create a new visual and tactile experience. With smooth lines, unique structure and high-end materials, it pays homage to nature while interpreting modern life.

NUMERATOR





INTRODUCING NUMERATOR

DESIGN BY COLLECTIVO

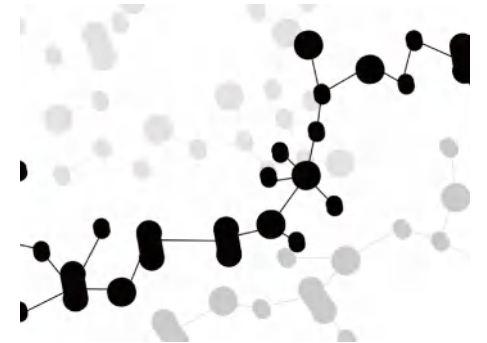

The lines of the molecular coffee table are smooth and dynamic, as if the trajectory of molecules in motion is frozen. Its unique structure ensures the stability of the coffee table while showcasing the designer's exquisite control over space and form.



SNOWCAP





PRODUCT SIZE

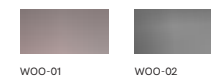
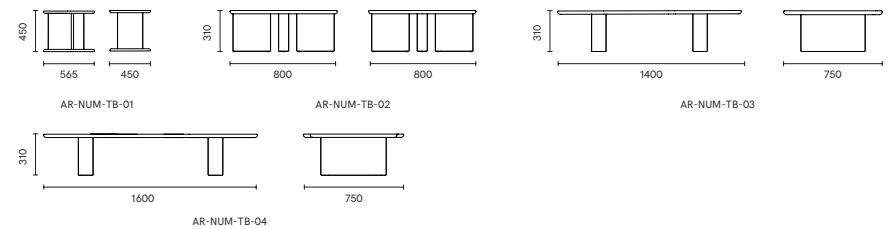

Material

FLOWER

Applicable products :

SYS- FLY- ET- UP-
BREAD- MOON-
CUT- PIPE- COLLAR-
WHALE- TAIL



VICO

Applicable products :

SYS- FLY- ET- UP-
BREAD- MOON-
CUT- PIPE- COLLAR-
WHALE- TAIL



HY

Applicable products :

SYS- FLY- ET- UP-
COLLAR- WHALE-
TAIL- MACAROON

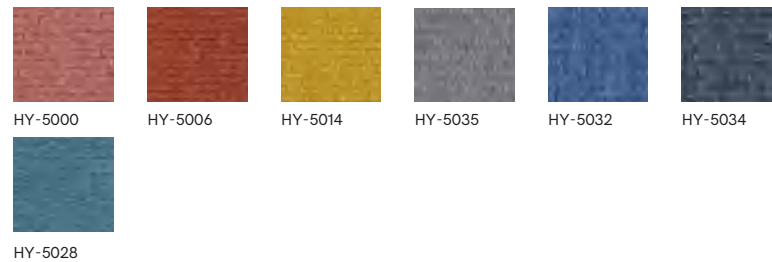

SUNDAY

Applicable products :

SANTO- KAS- CITY-
PIPE- BUONO



LIDO

Applicable products :

SANTO- KAS- FAN



MINA

Applicable products :

MELLO- SHEEP-
SQUARE- MOON

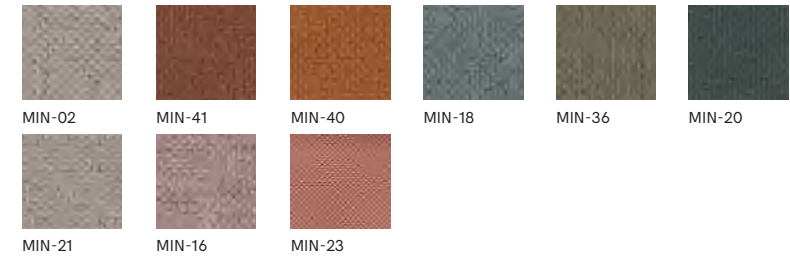

YM

Applicable products :

SYS- ALGER- CITY-
ROMA- PIPE- BUONO-
FAN- MOON

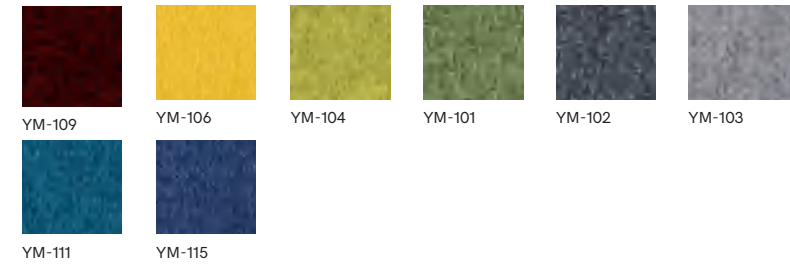

JA/JD

Applicable products :

ALGER- ROMA- BUOMO



LEA

Applicable products :

ALGER- SQUARE



ART

Applicable products :

ALGER- SQUARE



CREATING WORK GEMS



OFFICE PLANNER

Office Planner Pte Ltd

1 Commonwealth Lane

#09-01, 02, 03 One Commonwealth

Singapore 149544

Sales Enquiry : sales@o-planner.com

Office : +65 68356789



[f](#) [@](#) [in](#) / OfficePlanner

office-planner.com

